



**STACK
STACK
STACK**

Digital Video Recorders

DVR3 Harsh Environment Digital Video & Data Recorders

Stack's new range of Digital Video Recorders (DVRs) can be used as a conventional DVR to record video and audio. Now they can also record data as well as video, in one compact unit, for the ultimate in Synchronized Video-Logging!



Stack DVRs can be connected directly to any Stack Dash Display or Data logging system by CAN Bus. Up to 128 channels of data, including GPS and the internal 3-axis G-sensor channels, can be recorded with the video and audio. The recorded MPEG2 file can be played back directly on a DVD player or any PC media player.

Additionally the video and data can be viewed and analysed in the supplied Stack DataPro Analysis software. DataPro's data comparison mode enables two recordings to be precisely aligned based on time or 'track map' location, and video and data to be compared side-by-side.

Fully configurable, Stack's DVRs capture TV broadcast standard video and audio at up to 20Mbps (our VBR enabled DVR3-540 can record at more than 50 Mbps), directly onto a Compact Flash (CF) card. The image can be recorded in either 4:3 or 16:9 (widescreen) aspect ratio. The DVRs have an A/V output for connection to an external monitor or for use with a wireless link.

Recording can be triggered automatically using the built-in 3 axis G-sensor; alternatively use the included remote control record trigger switch with status LED, or control recording via the CAN interface.

Stack DVRs have a slim, lightweight design built for reliable operation in the harshest environments.



Key Features

- Video-Logging with synchronized recording of vehicle data channels.
- CAN bus interface for direct connection to data expansion modules or ECUs.
- 3 or 4 camera inputs with integrated configurable mixer.
- Metadata recording of up to 128 data channels at 1-500Hz sampling rates.
- Optional GPS (NMEA0183 interface) and vehicle data.
- Rugged, small and lightweight with no moving parts.
- Fully sealed to IP67 units available.
- Real time MPEG-2 compression of video and stereo audio.
- Up to 50 MBits/Sec for broadcast production use, with POV cameras.
- Record to removable Compact Flash (CF) Card, playable on a PC/laptop. Files can be burnt directly to DVD.
- Up to 128GB of memory, providing more than 72 hours of high quality, full resolution recording.
- Video recordings can be transferred to a PC over the USB link.
- Recordings can be viewed on external MPEG2 media player via USB.
- 16:9 or 4:3 screen ratios supported.
- Extended operating temperature range: -20 to +80°C (-4 to 176°F) available.
- Continuous Loop Recording modes.
- Event Recorder mode, with pre- and post-trigger record periods.
- Quick release sealed CF card door.
- External DVR status LED.
- Manual record switch as standard.
- Automatic record start/stop using built-in 3-axis G-sensor or any other channel.
- 9 to 20V DC powered (20 to 50V DC option).
- Brownout protection option records up to 1 second of video after power loss.
- No video loss on power supply failure option.
- Firmware upgrades via internet

IN-BUILT VIDEO MIXER

Stack's range of multiple camera DVRs incorporate an in-built multiple camera input (composite PAL or NTSC) video mixer. This allows any format of 1 to 3 or 4 cameras (depending on model) to be recorded simultaneously with programmable scale, crop, position, flip, mirror and position of each picture.

Stack's multiple camera input DVRs give the user full control over all screen elements with fully flexible picture-in-picture configuration.

The easy-to-use software utilises a simple click and drag interface to set up how each input channel is displayed. A live view of the arranged screen is available via the DVR's monitor output.

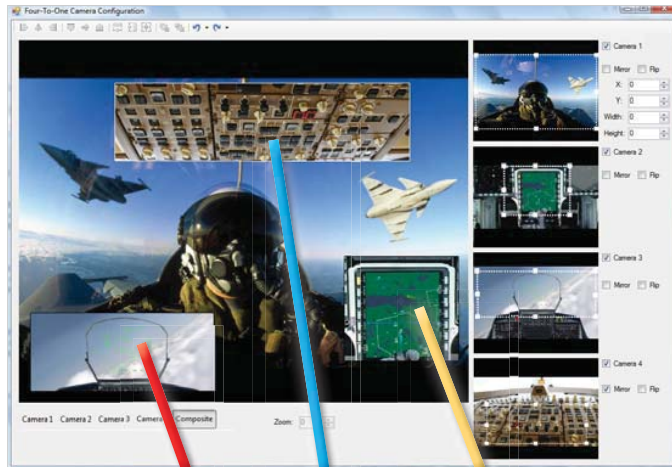

Crop Mirror/Flip Resize

EXTERNAL INTERFACES

Stack DVRs support a number of external interfaces. **NEW FOR 2011**, a CAN interface allows a DVR3 to be directly connected to one or more Stack data expansion modules or a third party ECU. A GPS receiver can also be connected to the DVR to provide speed, position, altitude, time and date information.

DATA OVERLAY

Data Overlay enables data from these CAN and/or GPS sources, together with the internal 3-axis G-sensor and internal real time clock, to be overlaid on the recorded video image. Positioning the data on the image is simple, using the drag-and-drop PC configuration software (below).

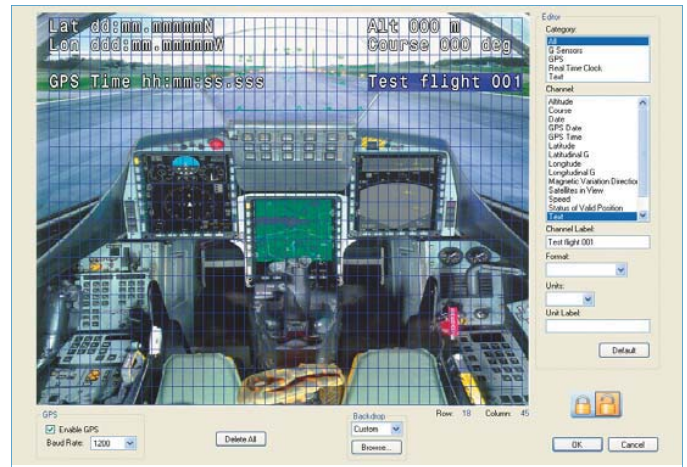

DVR CONFIGURATION SOFTWARE

All models in the Stack DVR range are supplied with our easy-to-use PC Configuration Utility, which makes set-up and configuration of the DVR quick and easy. It offers comprehensive flexibility and control over the DVR's operation including video and audio recording quality selection. The functionality of the external record switch can be configured, and the DVR record control can be based on the internal 3 axis G-sensor.

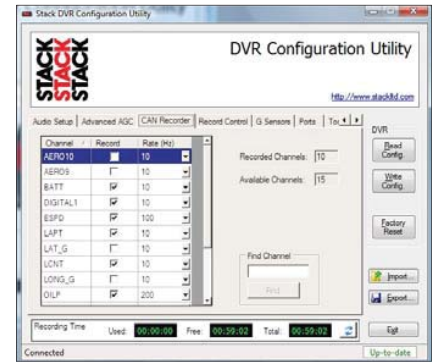
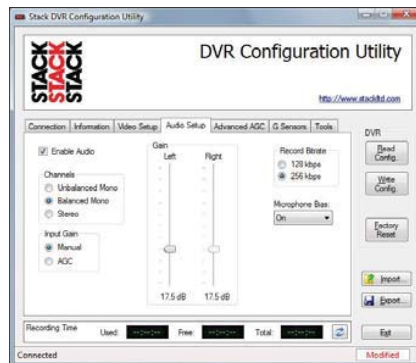
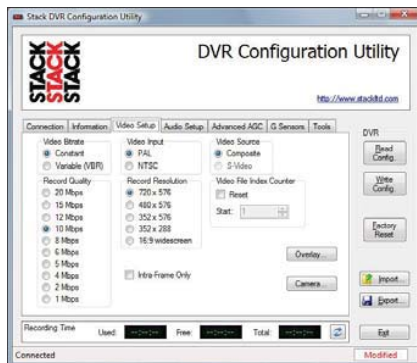

CAMERA MOUNTS, MOUNTS & ACCESSORIES

Stack supply the highest quality bullet cameras available (no – not all cameras are the same!). Our cameras have a specification of 560TVL, 0.1Lux with a 4.3mm lens (78° angle of view). Cameras are supplied with a waterproof connector, which mates directly with the connector on the DVR harness. Our comprehensive range of camera mounts ensure that there is a camera mount to meet every eventuality.



PAL/NTSC Bullet Cameras, 4.3mm lens, waterproof connector (ST8393 PAL / ST8394 NTSC)



Multi-directional roll-bar camera mount (Universal Fitting 30 - 50mm) (ST390080)



Multi-directional flat-panel camera mount (ST390081)



Multi-directional suction-cup camera mount (ST390082)

SYNCHRONIZED VIDEO-LOGGING

NEW FOR 2011, Stack DVRs have a built-in CAN interface, enabling connection to one or more Stack data expansion modules or a third party ECU, to provide synchronous video and audio recording with up to 128 data channels.

Data from the CAN interface, optional GPS receiver, plus the internal 3-axis G-sensor and real time clock, are recorded with the video and audio onto the CF card for subsequent replay and analysis using the Stack DataPro software supplied. Data channels can be recorded at an individual record rate of 1-500Hz.

A track-map can be calculated from the GPS data, or from inertial data (speed, lateral-g force). Any point on the trackmap can be selected with one mouse-click, allowing the user to navigate through the video and data with pinpoint precision. The user can compare two recordings from different runs, vehicles, etc. With the addition of side-by-side video playback, and single frame-stepping through the data, now you can literally 'see' the differences between two recordings.

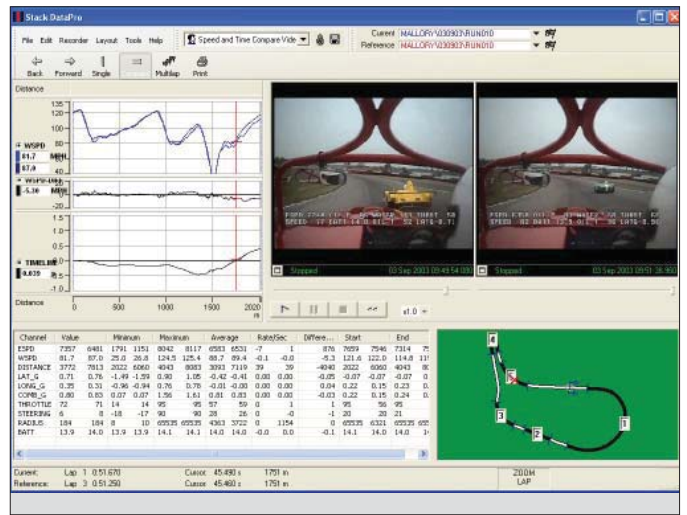
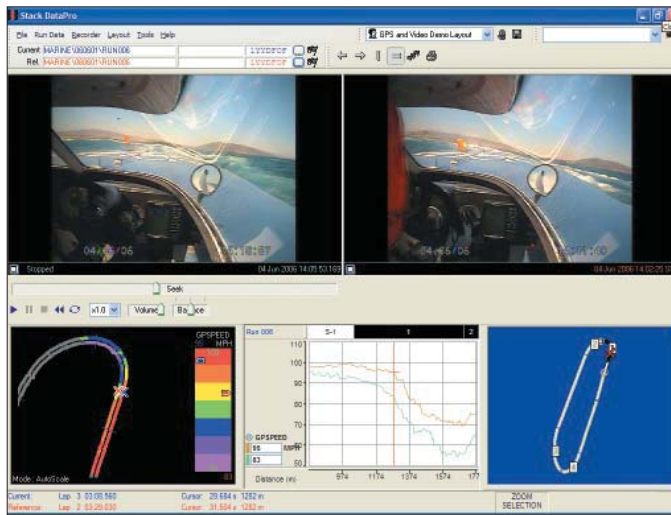

SYSTEM SCHEMATIC

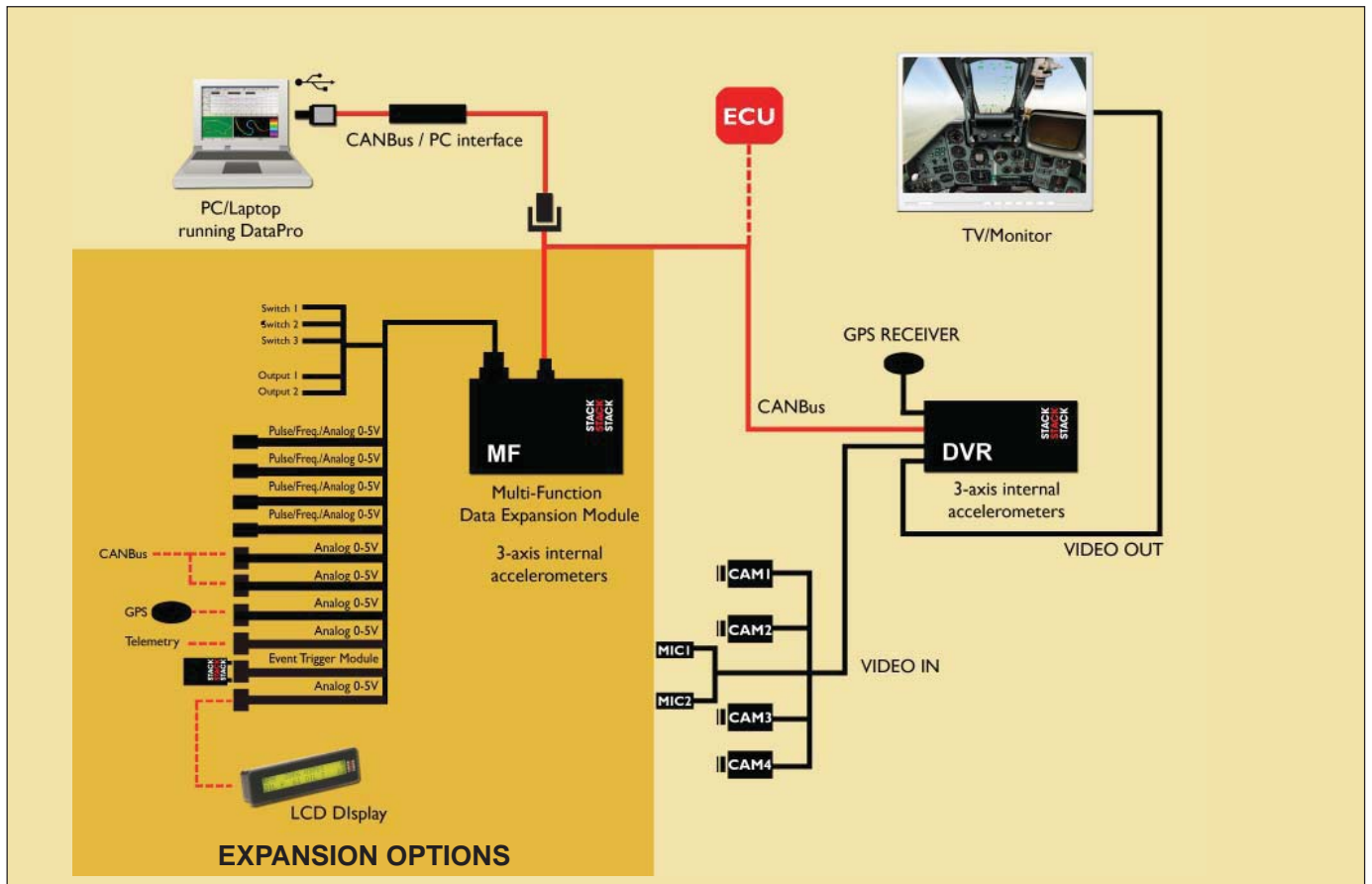

DVR3-130

3 CAMERA INPUTS

Stack's DVR3-130 is the perfect solution for applications that require reliability and toughness but not a fully waterproof unit.

In common with all of the DVR3 range, the DVR3-130 offers high-performance coupled with outstanding reliability.

Each Stack DVR comes complete with harnesses, including camera and mic' power outputs, record control switch and status lamp.



- 3 camera inputs
- 10 Fixed bit rates from 1 to 20 Mbps
- 16:9 Widescreen or 4:3 screen ratios
- 7-140 Mins/Gbyte @ full resolution recording time
- Metadata recording capability
- 128GB maximum card size
- 9 to 20V DC powered (20-50V DC option)
- 0 to 50°C operating temp. range
- External status LED
- Sealed CF card door (closed)
- Automatic stop/start recording with in-built 3-axis g sensor
- Continuous Loop Recording modes
- Event Recorder mode, with pre-and post-trigger record periods
- CAN Bus & GPS Receiver Inputs
- G-force or GPS data overlay option
- 1 sec. real-time date/time overlay

DVR3-240

4 CAMERA INPUTS

Stack's DVR3-240 offers "professional performance" even under the most difficult conditions including wet and/or high vibration environments.

The DVR3-240 has an IP67 standard waterproof rating and utilises MIL-type connectors.

The 128GB maximum card size allows longer continuous recording runs.



- 4 camera inputs
- 10 Fixed bit rates from 1 to 20 Mbps
- 16:9 Widescreen or 4:3 screen ratios
- 7-140 Mins/Gbyte @ full resolution recording time
- Metadata recording capability
- 128GB maximum card size
- 9 to 20V DC powered (20-50V DC option)
- 0 to 70°C operating temp. range
- External status LED
- Fully sealed to IP67
- Automatic stop/start recording with in-built 3-axis g sensor
- Continuous Loop Recording modes
- Event Recorder mode, with pre-and post-trigger record periods
- CAN Bus & GPS Receiver Inputs
- G-force or GPS data overlay option
- 1 sec. real-time date/time overlay
- Mil-type "AS" connectors

DVR3-440

4 CAMERA INPUTS

For the most demanding applications, the DVR3-440 can be used in harsh environments including high vibration and extreme temperatures.

The unit is waterproof to IP67 and boasts an extended operating temperature range of -20 to +80°C.

The 20 Mbps maximum fixed bit rate produces unmatched video quality.

The Brownout protection option ensures recording continuous despite power loss of up to a second.



- 4 camera inputs
- 10 Fixed bit rates from 1 to 20 Mbps.
- 16:9 Widescreen or 4:3 screen ratios
- 7-140 Mins/Gbyte @ full resolution recording time
- Metadata recording capability
- 128GB maximum card size
- 9 to 20V DC powered (20-50V DC option)
- 20 to 80°C operating temp. range
- External status LED
- Fully sealed to IP67
- Automatic stop/start recording with in-built 3-axis g sensor
- Continuous Loop Recording modes
- Event Recorder mode, with pre-and post-trigger record periods
- CAN Bus & GPS Receiver Inputs
- G-force or GPS data overlay option
- 1 sec. real-time date/time overlay (0.01 sec. overlay option)
- Mil-type "AS" connectors
- 20g continuous vibration rating
- 50g shock rating
- Brownout protection option

DVR3-540

4 CAMERA INPUTS

With stunning picture quality, the DVR3-540 captures video and audio that is equivalent or better than DV tape but is immune to the susceptibility of non solid-state devices to shock, vibration and temperature.

In VBR mode, the DVR3-540 can achieve bit-rates in excess of 50Mbps - dependant on image content.

Another key feature is Intra-frame (I-frame) only record mode - a great benefit to video professionals using a non-linear editing system such as Avid or Final Cut Pro.



- 4 camera inputs
- 10 Fixed bit rates from 1 to 20 Mbps + VBR up to 50 Mbps
- 16:9 Widescreen or 4:3 screen ratios
- 3-140 Mins/Gbyte @ full resolution recording time
- Metadata recording capability
- 128GB maximum card size
- 9 to 20V DC powered (20-50V DC option)
- 20 to 80°C operating temp. range
- External status LED
- Fully sealed to IP67
- Automatic stop/start recording with in-built 3-axis g sensor
- Continuous Loop Recording modes
- Event Recorder mode, with pre-and post-trigger record periods
- CAN Bus & GPS Receiver Inputs
- G-force or GPS data overlay option
- 1 sec. real-time date/time overlay (0.01 sec. overlay option)
- Mil-type "AS" connectors
- 20g continuous vibration rating
- 50g shock rating
- Brownout protection option

© STACK LIMITED 2011

In the interests of continuous product improvement, we reserve the right to alter without notice the specifications and features described in this leaflet.
Stack Limited, Bicester OX26 4UL UK. Tel: +44 (0) 1869 240404 Email: sales@stackltd.com Web: www.stackltd.com
Stack Inc, Sycamore, IL. 60178 USA. Tel: (888) 867 5183 Email: sales@stackinc.com Web: www.stackinc.com

080511(2)



www.instrumentation.it

Via Acquanera 29, 22100 COMO (Italy) tel. +39.031.525391 - fax +39.031.507984 - info@instrumentation.it

INSTRUMENTATION DEVICES SRL