

CTP16-Rotate

16 channel telemetry for rotating applications like wheels or rotors, high signal bandwidth, 16bit, software programmable



- Inputs for STG, TH-K, ICP, VOLT ...
- Simultaneous sampling
- 16 bit resolution
- Software programmable
- Signal bandwidth: 16 x 0-6000Hz
- Battery power up to 8-10h
- Radio telemetry transmission
- Output analog +/- 10V
- Digital data interface to PC (option)
- Waterproofed ENC housing (IP65)

General functions:



The CTP16-Rotate is a 16-channel telemetry system for rotating applications with integrated signal conditioning for sensor signals, wireless digital transmission and analog reproduction.

In the encoder/transmitter unit the sensor signals are conditioned, filtered (anti-aliasing) and digitized (16-bit). Simultaneous sampling is provided for all channels. Finally, the PCM encoded data is transmitted via radio frequencies to the receiver.

Various configurations of different sensor modules are available incl. signal conditioning for strain gages (STG), thermocouples type K (TH-K), Pt100/1000, ICP sensors, potentiometer sensors (POT) and also voltage inputs. Mixed configuration available (2-CH-steps).

All sensor modules are software programmable via LAN-Adapter. The LAN-Adapter has an integrated web interface and enables easy access to modules!

The stationary receiver provides 16 +/-10V analog outputs via Sub-D male socket (option: digital PC interface).

The analog signal bandwidth is 0-375 Hz (320kbit) and up to 0-6000Hz (5000kbit) for 16 channels. The measurement accuracy is $\pm 0.2\%$ (without sensor). The CTP16-Rotate is specified for operational temperatures from -20°C to $+70^{\circ}\text{C}$. The maximum distance between transmitter and receiving antenna is approx. 10-20 m (30-60 feet) – depending on the application! Mixed configuration available (2-CH-steps).

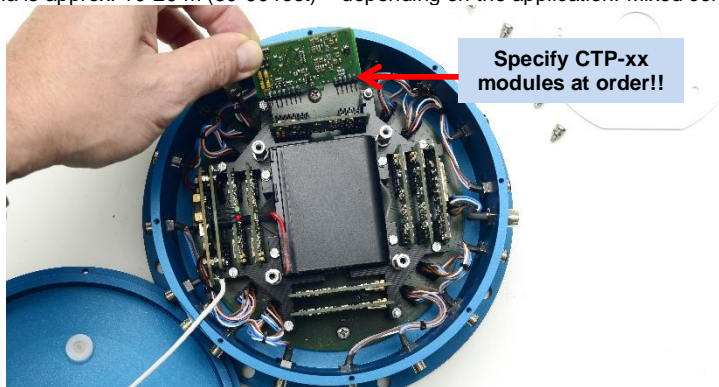

Frequency table	Cut off frequency from anti-aliasing filter (-3dB) and sampling rate (see red)
Bit rate	16 CH.
5000kbit	6000Hz (15625Hz)
2500kbit	3000Hz (7812.50Hz)
1250kbit	1500Hz (3906.25Hz)
625kbit	750Hz (1953.125Hz)
312.5kbit	375Hz (976.56Hz)



CTP16-Rotate Transmitting Unit Technical Data (Encoder)



Encoder in IP65 Aluminum housing

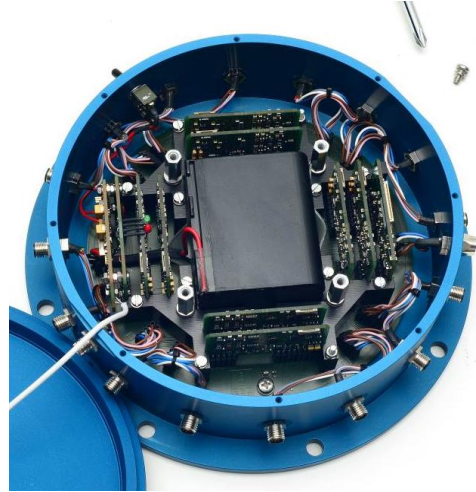

Encoder inside

CTP acquisition modules (rotor side)

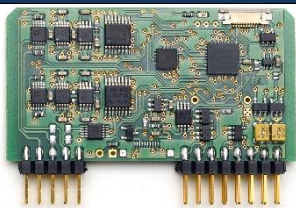

CTP-STG-V3
Acquisition module for 2 strain gages
Full, half and quarter bridge ($\geq 350\Omega$)
Fixed excitation 4V DC
Offset calibration by auto zero
Manual offset shifting after auto zero
Gain: 125-250-500-1000-2000
Test shunt-cal step
Signal bandwidth 0Hz to 6000Hz*
Resolution 16bit
Accuracy <0.2%
Current consumption with full bridge 350 ohm 75mA

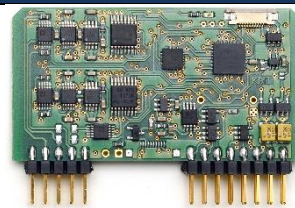

CTP-VOLT-V3
Acquisition module for 2x high level inputs
Range: $\pm 0,625V$, $\pm 1,25V$, $\pm 2,5V$, $\pm 5V$, $\pm 10V$
Signal bandwidth 0Hz to 6000Hz*
(*see table of cut-off-frequency)
Resolution 16bit
Accuracy <0.2%
Current consumption 60mA

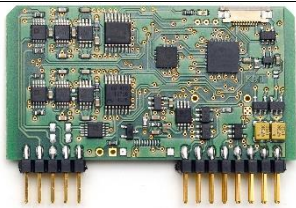

CTP-ICP-V3
Acquisition module for 2 ICP sensors
Current EXC. 4mA, 28V
Gain: 1-2-4-8-16-32
Signal bandwidth 3 Hz to 6000Hz*
(*see table of cut-off-frequency)
Resolution 16bit
Accuracy <0.2%
Current consumption 100mA

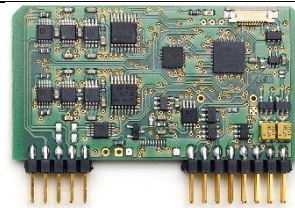

CTP-TH-K-V3
Acquisition module for 2x TH-K
Inputs galvanic isolated
Range -50 to 1000°C, -50 to 500°C
or -50 to 250°C
Cut-off filter 30Hz (more on request)
Resolution 16bit
Accuracy: 0.2% at 1000°C range
Current consumption 110mA

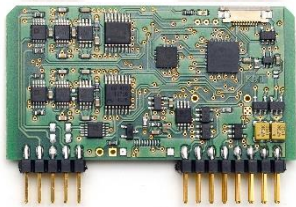

CTP-Pt100/1000 (RTD) V3
Acq. module for 2 RTD sensors
Range -100 to 600°C, -50 to 300°C
or -25 to 150°C
Type Pt100 or Pt1000
Current EXC. 1mA
Connection: 4-, 3- and 2 wire
Sensor break detection
Signal bandwidth 6Hz
Resolution 16bit
Accuracy <0.2%
Current consumption 60mA

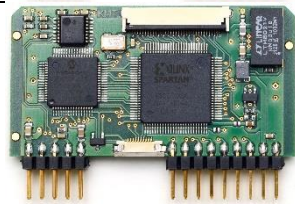

CTP-CONTROL-V3
Controller 1- 32 acquisition modules
Output: PCM
Programmable via LAN adapter
Current consumption 40mA, with LAN-adapter 140mA

System Parameters ENCODER:

Channels:	16
Resolution:	16 bit A/D converter with anti-aliasing filter, simultaneous sampling of all channels
Line-of-sight distance:	up to 20m (depends of application and bit rate)
Powering:	Li Ion Accumulator 7.2V, 7800mA, capacity up to 8-10 hours
Power consumption:	700 mA using 16x STG full bridge sensors 350 Ohms
Analog signal bandwidth:	See table
Transmission:	Digital PCM Miller format - FSK
Transmission Power:	10mW!
Dimensions:	Diameter 190mm, bottom plate diameter 220mm, height 70mm (without antenna)
Weight:	2.00kg without sensor cables and antenna
Operating temperature:	- 20 ... +70°C
Housing:	Aluminum anodized, waterproofed (IP65)
Humidity:	20 ... 80% no condensing
Vibration:	5g Mil Standard 810C, Curve C
Static acceleration:	100g in all directions, 2000 RPM
Shock:	200g in all directions

Technical specifications are subject to change without notice!

CTP-DEC16 Receiver unit for max 16 Channels output via 37 pol. Sub D (radio transmission version with diversity receiver 312.5 ... 1250kbit)

Front side view

Female 37 pole Sub-D for analog signal output, CH 1 to 16



Rear side view

Auto Zero LED
Bright on, if analog output is over 60mV

Low Pwr LED ON = BATT empty!

Power Switch

Transmission error LED
Fuse of powering defect LED

7-pole female TUCHEL connector for power supply input (10-30V DC)

PCM out for IP-LAN-Interface (Opt.)

AZ 1-8 9-16

Level

HF -Field strength display

SMA antenna connector with active LED of antenna (diversity)

DC 10-30V

Antenna

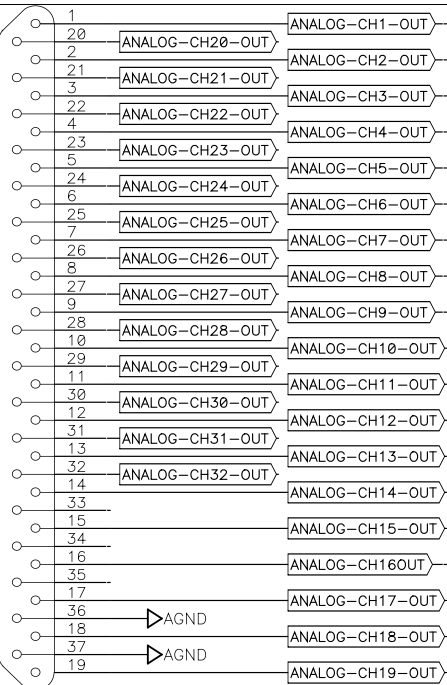

Plug-side

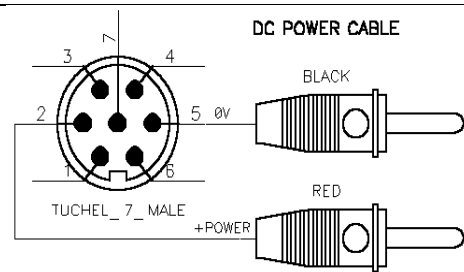

Optional BNC16 Box. Connect on 37pol Sub-D

CTP-DEC16 System Parameters:

Channel:	16 x +/-10V analog outputs via Sub-D male socket
Resolution:	16 bit D/A converter, with smoothing filter
Power supply input:	10-30 VDC, power consumption <24 Watt
Transmission:	Digital PCM Miller Format – FSK,
Dimensions:	205 x 105 x 65mm
Weight:	1.25 kg without cables and antenna
Overall system accuracy between encoder input and decoder output:	+/-0.25% without sensor influences
Environmental	
Operating:	-20 ... +70°C
Humidity:	20 ... 80% not condensing
Vibration:	5g
Static acceleration:	10g in all directions
Shock:	100g in all directions

CTP-DEC16 Receiver unit for max 16 Channels output via 37 pol. Sub D (radio transmission version via quad receiver for 2500kbit and 5000kbit)

Front side view

Female 37 pole Sub-D for analog signal output, CH 1 to 16



Rear side view

GND cable to ground the housing

Low Pwr LED ON = BATT empty!

Power ON LED

Power Switch

Transmission error LED
Fuse of powering defect LED

7-pole female TUCHEL connector for power supply input (10-30V DC)

CTP - DEC16

ON
DC 10-30V

Low Pwr
Error
Fuse

PCM IN
coming from HF-BOX

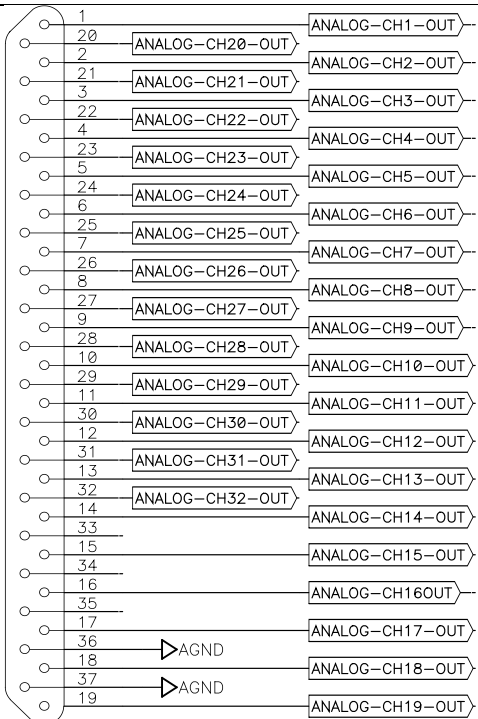

Plug-side

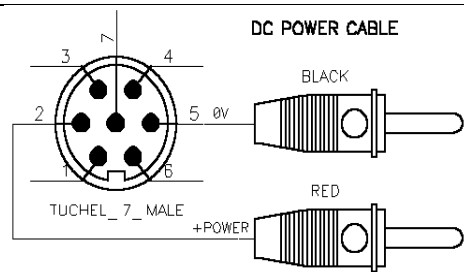

Optional BNC16 Box. Connect on 37pol Sub-D

CTP - DEC16 System Parameters:

Channels:	16 x +/-10V analog outputs via Sub-D male socket
Resolution:	16 bit D/A converter, with smoothing filter
Power supply input:	10-30 VDC, power consumption <24 Watt
Analog signal bandwidth:	see frequency table
Transmission:	Digital PCM Format
Dimension:	205 x 105 x 65mm
Weight:	1.00kg without cables and antenna
Overall system accuracy between encoder input and decoder output:	+/-0.2% without sensor influences
Environmental	
Operating:	-20 ... +70°C
Humidity:	20 ... 80% not condensing
Vibration:	5g
Static acceleration:	10g in all directions
Shock:	100g in all directions

CTP-DEC16 Receiver unit for max 16 Channels output via 37 pol. Sub D (radio transmission version via quad receiver for 2500kbit and 5000kbit)

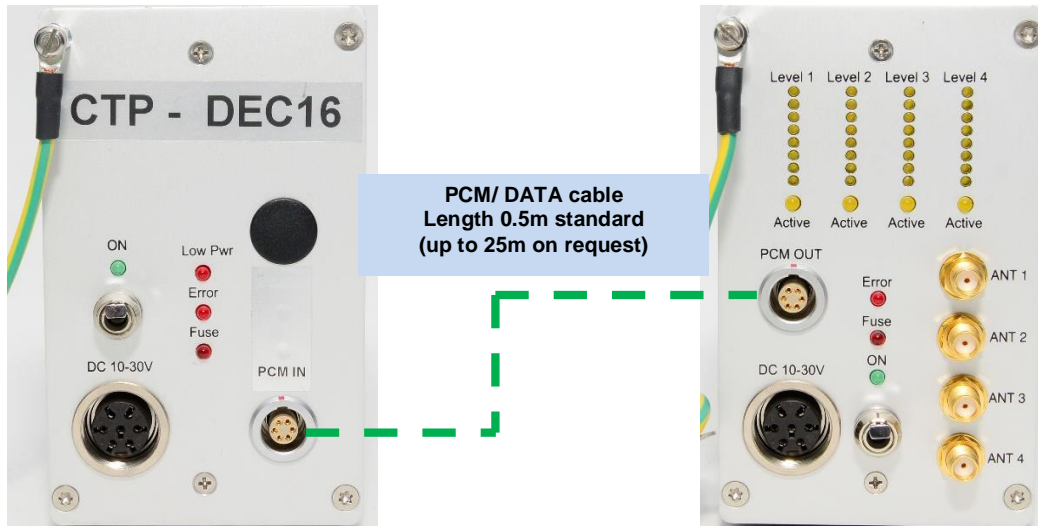
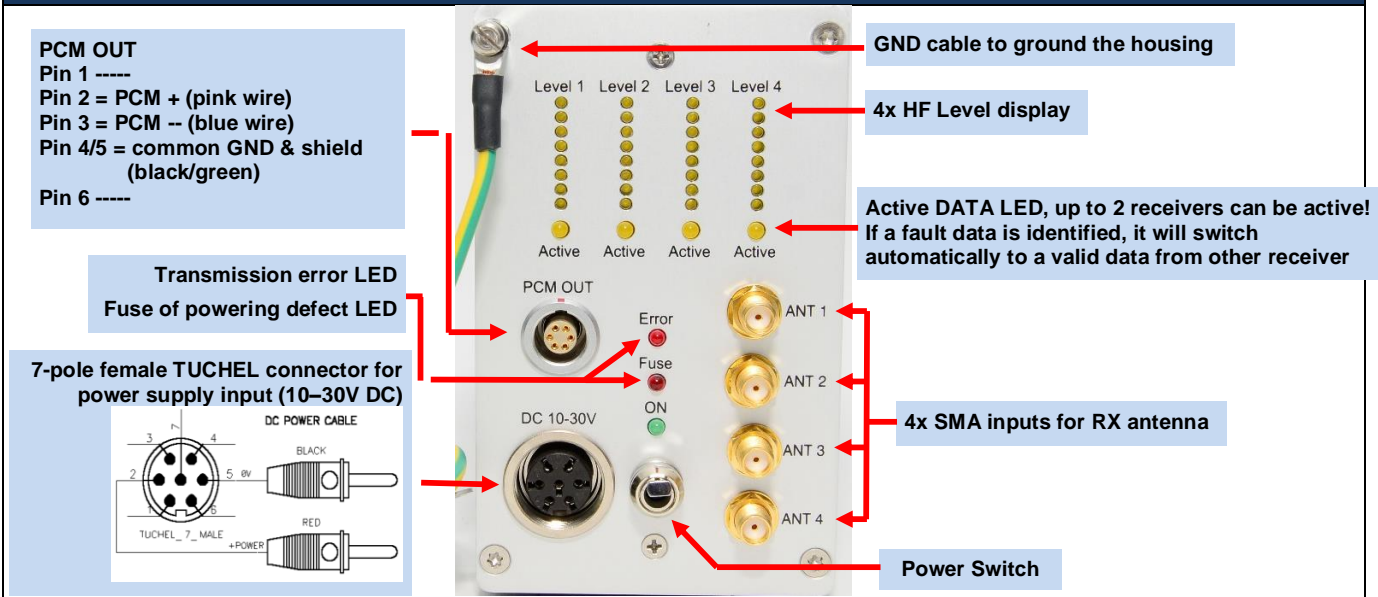

HF BOX Quad System Parameters:

HF receivers	4
Antenna connection	SMA
Output	PCM
Power supply input:	10-30 VDC, power consumption <24 Watt
Dimensions:	205 x 105 x 65mm
Weight:	1.05 kg without cables and antenna
Environmental	
Operating:	-20 ... +70°C
Humidity:	20 ... 80% not condensing
Vibration:	5g
Static acceleration:	10g in all directions
Shock:	100g in all directions