

ERAD4000

HARDWARE AND SOFTWARE MANUAL

SOFTWARE VERSION 2.22

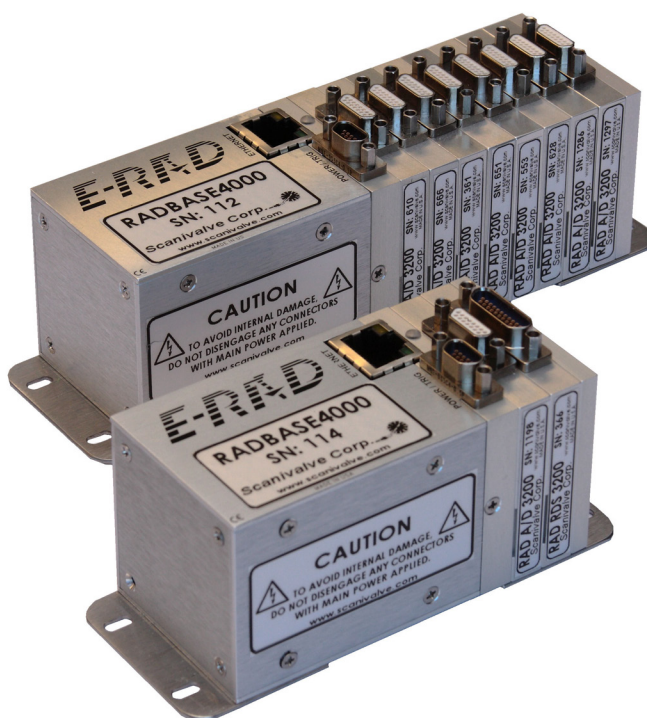

Scanivalve



Instrumentation Devices Srl
Via Acquanera 29 - 22100 COMO (Italy)
ph +39 031 525 391- fax +39 031 507 984
info@instrumentation.it - www.instrumentation.it

PREFACE

WARNINGS, CAUTIONS AND NOTES



WARNING

The WARNING! symbol indicates that danger of injury for persons and the environment and/or considerable damage (mortal danger, danger of injury) will occur if the respective safety precautions are not taken.



CAUTION

The CAUTION ! symbol indicates danger for the system and material if the respective safety precautions are not taken.



The ESD note symbol indicates that proper precautions for handling Electrostatic Sensitive Devices needs to be taken when performing the related operation. This includes the use of grounded work surfaces and personal wrist straps to prevent damage to sensitive electronic components.

WARRANTY

Scanivalve Corporation, Liberty Lake, Washington, hereafter referred to as Seller, warrants to the Buyer and the first end user that its products will be free from defects in workmanship and material for a period of twelve (12) months from date of delivery. Written notice of any claimed defect must be received by Seller within thirty (30) days after such defect is first discovered. The claimed defective product must be returned by prepaid transportation to Seller within ninety (90) days after the defect is first discovered. Seller's obligations under this Warranty are limited to repairing or replacing, at its option, any product or component part thereof that is proven to be other than as herein warranted.

Surface transportation charges covering any repaired or replacement product or component part shall be at Seller's expense; however, inspection, testing and return transportation charges covering any product or component part returned and redelivered, which proves

not to be defective, shall be at the expense of Buyer or the end user, whichever has returned such product or component part.

This Warranty does not extend to any Seller product or component part thereof which has been subjected to misuse, accident or improper installation, maintenance or application; or to any product or component part thereof which has been repaired or altered outside of Seller's facilities unless authorized in writing by Seller, or unless such installation, repair or alteration is performed by Seller; or to any labor charges whatsoever, whether for removal and/or reinstallation of the defective product or component part or otherwise, except for Seller's labor charges for repair or replacement in accordance with the Warranty. Any repaired or replacement product or component part thereof provided by Seller under this Warranty shall, upon redelivery to Buyer, be warranted for the unexpired portion of the original product warranty.

THIS WARRANTY IS IN LIEU OF AND EXCLUDES ALL OTHER WARRANTIES, EXPRESS OR IMPLIED, ARISING BY OPERATION OF LAW OR OTHERWISE, INCLUDING THE IMPLIED WARRANTIES OF MERCHANTABILITY AND FITNESS FOR A PARTICULAR PURPOSE, AND IN NO EVENT SHALL SELLER BE LIABLE FOR INCIDENTAL OR CONSEQUENTIAL DAMAGES.

In the event of a failure:

1) Notify Scanivalve Corporation, Customer Service Department. Include model number and serial number. On receipt of this information, service data or shipping instructions will be forwarded. This may be transacted by telephone or e-mail.

2) On receipt of shipping instructions, forward the product, transportation prepaid. Repairs will be made and the product returned.

3) All shipments should be made via "Best Way". The product should be shipped in the original packing container or wrapped in protective material and surrounded by a minimum of four (4) inches of a shock absorbing material.

TRADEMARKS ® AND COPYRIGHTS ©

Scanivalve is a registered trademark of Scanivalve Corporation.

All other brand and product names are trademarks or registered trademarks of their respective companies.

PACKAGING FOR SHIPMENT

If the product must be shipped, whether being returned to Scanivalve or relocated to another location it must be packaged properly to minimize the risk of damage. The recommended method of packing is to place the instrument in a container, surrounded on all sides with at least four inches of shock attenuating material such as Styrofoam peanuts.

IMPORTANT NOTICE

Please note that the product specifications and other information contained in this manual are subject to change without notice. Scanivalve Corporation makes an effort and strives to provide complete and current information for the proper use of the equipment. If there are any questions regarding this manual or the proper use of the equipment, contact Scanivalve Corporation.

CONTACT INFORMATION

If there are any questions or concerns regarding any Scanivalve product please do not hesitate to contact us at the following:

Scanivalve Corp.
1722 N. Madson Street
Liberty Lake, WA 99019
Telephone: (800)935-5151 (509)891-9970
Fax: (509)891-9481
scanco@scanivalve.com
www.scanivalve.com

Scanivalve Corporation is an ISO 9001:2015 certified company.

This page is intentionally left blank

TABLE OF CONTENTS

| | |
|---|-----------|
| PREFACE | IV |
| Warnings, Cautions and Notes | iv |
| Warranty | iv |
| Trademarks ® and Copyrights © | v |
| Packaging for Shipment | v |
| Important Notice | v |
| Contact Information | v |
| | |
| SECTION 1: SPECIFICATIONS | 8 |
| General Specifications | 8 |
| Environment Specifications | 8 |
| | |
| SECTION 2: INTRODUCTION | 10 |
| ERAD4000 General Description | 10 |
| Environmental considerations | 10 |
| ERAD4000 Power Requirements | 11 |
| Ethernet Connection | 12 |
| Configuration Connection | 12 |
| Digital I/O Connections via RDS3200 | 13 |
| ZOC Input Connections | 14 |
| RAD A/D 3200- Remote A/D Modules | 15 |
| Software | 15 |
| Rad4000.hex | 15 |
| | |
| SECTION 3: OPERATION | 16 |
| Unpack & Inventory | 16 |
| Mounting | 16 |
| Warm-up | 16 |
| Communications | 16 |
| Configuration Port | 16 |
| Ethernet Communications | 16 |
| IP Address | 17 |
| Client/Host Options | 17 |
| PC - TCP/IP | 17 |
| PC - UDP | 17 |
| PC - ScanTel | 17 |
| PC - LabVIEW Configuration Utility | 17 |
| PC - LabVIEW Development Kit | 17 |
| PC - HyperTerminal | 17 |
| DIP Switch Settings | 18 |
| Modules | 18 |
| DSP Boot Loader | 18 |
| FTP | 18 |
| Boot Loader and Application File System | 18 |

| | |
|--|-----------|
| Host Communication | 19 |
| Commands | 19 |
| Network Attached Storage (NAS) Operation | 19 |
| NAS Setup for use with a ERAD4000 | 20 |
| Local Host Computer Setup as a NAS | 20 |
| Network Time Protocol | 20 |
| Calibration | 20 |
| ERAD4000 Module Coefficient Installation | 20 |
| External Trigger | 20 |
| Hardware Trigger | 20 |
| Software Trigger | 20 |
| Special Procedures | 20 |
| Internet Explorer Setup | 21 |
| ERAD4000 Firmware Installation (Windows Xp & 7) | 21 |
| ERAD4000 Calibration Coefficient Installation (Windows XP & 7) | 22 |
| Operation in Bootloader Mode | 22 |
| Long Input Cable Application | 23 |
| | |
| SECTION 4: SOFTWARE | 24 |
| ERAD4000 Commands | 24 |
| Command Format | 24 |
| Command List | 25 |
| A/D Calibration | 25 |
| A/D Coefficient Calculation | 25 |
| Bank A Mode | 26 |
| Bank B Mode | 26 |
| Bank User Mode | 26 |
| Bootloader Version | 27 |
| Calibrate Insert | 27 |
| Calibrate Zero | 28 |
| Channel | 29 |
| Clear | 29 |
| Clear Accumulated Error Buffer | 30 |
| Control Pressure Reset | 30 |
| Delete | 31 |
| Delta | 32 |
| DOUT | 33 |
| Error | 33 |
| File | 34 |
| Fill | 34 |
| Get Accumulated Errors | 35 |
| Insert | 36 |
| List A/D Correction Table | 37 |
| List All Conversion Coefficients | 38 |
| List Bootloader Group Variables | 39 |
| List Calibration Variables | 40 |
| List Digital Variables | 41 |
| List Files | 41 |
| List Gain Variables | 42 |
| List ID Chip Identification | 43 |
| List ID Chip Settings | 44 |
| List Identification Variables | 45 |

| | |
|---|-----------|
| List Master Conversion Coefficients | 46 |
| List Module Information Variables | 47 |
| List Network Attached Storage Variables | 48 |
| List Offset Variables | 49 |
| List Profile List Settings | 50 |
| List Real Time Data Analysis Settings | 51 |
| List Scan Variables | 52 |
| List Scan Group Variables | 53 |
| List System Components | 54 |
| List Syslog Variables | 56 |
| Purge | 56 |
| Read | 57 |
| Read Digital Output | 57 |
| Reboot | 57 |
| Reset Sequence Number | 58 |
| Restart | 58 |
| Save | 58 |
| Save Bootloader Variables | 59 |
| Save Configuration Variables | 59 |
| Save Network Attached Storage Variables | 59 |
| Scan | 60 |
| Set | 61 |
| Slots | 62 |
| Status | 63 |
| Stop | 63 |
| Temperature | 64 |
| Temperature Gradient Compensation | 65 |
| Time Availability Test | 66 |
| Version | 66 |
| Write ID Chip Variables | 67 |
| Zero | 68 |
| Zero Load | 68 |
| Configuration Variables | 69 |
| General Scan Variables (Group S) | 69 |
| ADTRIG | 69 |
| BINADDR | 69 |
| IFC | 69 |
| Period | 70 |
| Scantrig | 70 |
| FM | 70 |
| PAGE | 70 |
| QPKTS | 71 |
| TEMPPOLL | 71 |
| TimeStamp | 71 |
| Conversion Variables (Group C) | 72 |
| BIN | 72 |
| CALAVG | 72 |
| CALPER | 73 |
| CALZDLY | 73 |
| CVTUNIT | 73 |
| EU | 73 |
| FILLONE | 74 |
| MAXEU | 74 |

| | |
|--|----|
| MINEU | 74 |
| MPBS | 74 |
| STARTCALZ | 75 |
| UNITSCAN | 75 |
| ZC | 75 |
| Digital Output Configuration Variables (Group D) | 76 |
| DLYPG | 76 |
| DLYPGSEQ | 76 |
| DOUTCALZ | 76 |
| DOUTPG | 76 |
| DOUTPGSEQ | 76 |
| DOUTPU | 77 |
| DOUTSCAN | 77 |
| DOUTREADY | 77 |
| BANKA | 77 |
| BANKB | 77 |
| BANKUSR | 78 |
| Scan Group Configuration Variables (Group G1 through G8) | 79 |
| AVG1 | 79 |
| CHAN1 | 79 |
| FPSn | 80 |
| SGENABLE | 80 |
| SGENABLEn | 80 |
| Module Configuration Variables (M1 through M8) | 81 |
| ENABLEn | 81 |
| HPRESSn | 81 |
| LPRESSn | 81 |
| MODTEMPn | 81 |
| NEGPTSn | 82 |
| NPRn | 82 |
| NUMPORTSn | 82 |
| TYPEn | 82 |
| Module Profile Variables (Group P) | 83 |
| RAD4000SN | 83 |
| SNn | 83 |
| Identification Configuration Variables (Group I) | 84 |
| AUX | 84 |
| AUXSCHED | 84 |
| CAL | 84 |
| CALSCHED | 84 |
| CONOUT | 84 |
| DISPIN | 84 |
| ECHO | 85 |
| FORMAT | 85 |
| HAVEARINC | 85 |
| HAVENET | 85 |
| IFUSER | 85 |
| NETIN | 86 |
| NETOUT | 86 |
| NL | 86 |
| RESCAN | 86 |
| TWOAD | 86 |
| ID Chip Configuration Variables (Group ID) | 87 |

| | |
|--|-----|
| IDP | 87 |
| Temperature Offset Variables (Group O) | 89 |
| TEMPBn | 89 |
| Temperature Gain Variables (Group G) | 89 |
| TEMPMn | 89 |
| Bootloader IP Configuration Variables | 90 |
| IPADDR | 90 |
| SUBNET | 90 |
| MAC | 90 |
| LOGIN | 90 |
| PASSWORD | 91 |
| LOGIN1 | 91 |
| PASSWORD1 | 91 |
| ALLOWANON | 91 |
| APP | 91 |
| GW | 92 |
| Network Attached Storage Configuration Variables (Group NAS) | 93 |
| ENNAS | 93 |
| ENNTP | 93 |
| FILENAS | 94 |
| IPNAS | 94 |
| IPNTP | 94 |
| PASSNAS | 94 |
| PATHNAS | 94 |
| USERNAS | 95 |
| UTCOFFSET | 95 |
| Real Time Data Analysis Group Configuration Variables (Group SA) | 96 |
| SA | 96 |
| SAACCUM | 97 |
| SAROLLAVG | 97 |
| SAMAX | 97 |
| SAMIN | 98 |
| SARMS | 98 |
| SASDEV | 98 |
| SAAVGXO | 98 |
| SAOL | 98 |
| READMODE | 99 |
| SYSLOG Variables (Group SYSLOG) | 100 |
| ENSYSLOG | 100 |
| LEVEL | 100 |
| IPSYSLOG | 100 |
| ERAD4000 ID Chip Data Format | 101 |
| Permanent Memory Data Format | 101 |
| EEPROM Memory Data Format | 102 |
| Network Attached Storage (NAS) Operation | 104 |
| NAS Setup for Use with a ERAD4000 | 104 |
| Local Host Computer Setup as a NAS | 104 |
| Dual Telnet Information | 104 |
| Scanivalve DSP Boot Loader | 105 |
| FTP | 105 |
| Boot Loader and Application File System | 105 |

| | |
|--|-----|
| DIP Switch Settings | 105 |
| Host Communication | 106 |
| Commands | 106 |
| ERAD4000 Scan Function | 107 |
| Internal Trigger | 107 |
| External Trigger | 107 |
| Hardware Trigger | 108 |
| Software Trigger | 108 |
| ERAD4000 Data Selection Chart | 109 |
| Notes for Data Selection Chart | 110 |
| ERAD4000 Profile File | 110 |
| Module Profile File | 110 |
| Binary Scan Packets | 111 |
| Packets without Module-Port Information | 111 |
| Packets with Module-Port Information | 111 |
| ASCII Data Transfer | 112 |
| Examples: | 112 |
| APPENDIX A - Temperature Compensated Pressure Conversion | 114 |
| Formulas: | 114 |
| APPENDIX B - Engineering Unit Conversion Constants | 115 |
| APPENDIX C - Software Change Log | 116 |

This page is intentionally left blank

SECTION 1: SPECIFICATIONS

GENERAL SPECIFICATIONS

| | |
|-------------------------------|---|
| Size (WxHxD) | |
| RAD Base: | 2.68in x 1.75in x 1.75in(68.07mm x 44.45mm x 44.45mm) |
| A/D Module: | 0.31in x 1.75in x 1.75in(7.87mm x 44.45mm x 44.45mm) |
| RDS Module: | 0.45in x 1.75in x 1.75in(11.43mm x 44.45mm x 44.45mm) |
| Weight | |
| RAD Base | 0.31lbs (141g) |
| A/D Module | 0.05lbs (23g) |
| RDS Module | 0.05lbs (23g) |
| Inputs | 1 to 8 A/D Modules |
| Channel Inputs | 512 Maximum |
| Modules Supported: | ZOC17, ZOC22B, ZOC23B ZOC33, MPS4164, ZOCEIM |
| Interface Connectors | |
| RAD Power | Cannon MDM-9PH003L-A174 |
| A/D Module | Cannon MDM-15SL2P |
| Ethernet | RJ45 |
| Power Requirements | |
| RAD Base | +15Vdc @ 41mA -15Vdc @ 4mA +5Vdc @ 300mA |
| A/D Module(Each) | +15Vdc @ 105mA -15Vdc @ 5.5mA |
| ZOC Module(Each) | +15Vdc @ 120mA -15Vdc @ 16 - 30mA |
| MPS Module (Each) | +15Vdc @ 120mA -15Vdc @ 30mA |
| External Trigger | 9 to 15Vdc @ 6.5mA |
| Communications Protocol | Ethernet 100Base-T |
| Maximum Data Acquisition Rate | 625 Hz Binary UDP for a 512 Channel system |

ENVIRONMENT SPECIFICATIONS

| | |
|-----------------------|-----------------------------|
| Operating Temperature | 5 to 60 °C |
| Humidity | 5 to 95% RH, Non-Condensing |
| Shock & Vibration | MIL-STD-810G |
| Shock | 7.70G |
| Vibration | 7.70G |
| Acceleration | 7.70G |

81243-1

NOTES:
 1. REFER TO DRAWING #21355 FOR PRODUCT DETAILS.
 2. DIMENSIONS IN INCHES [mm]

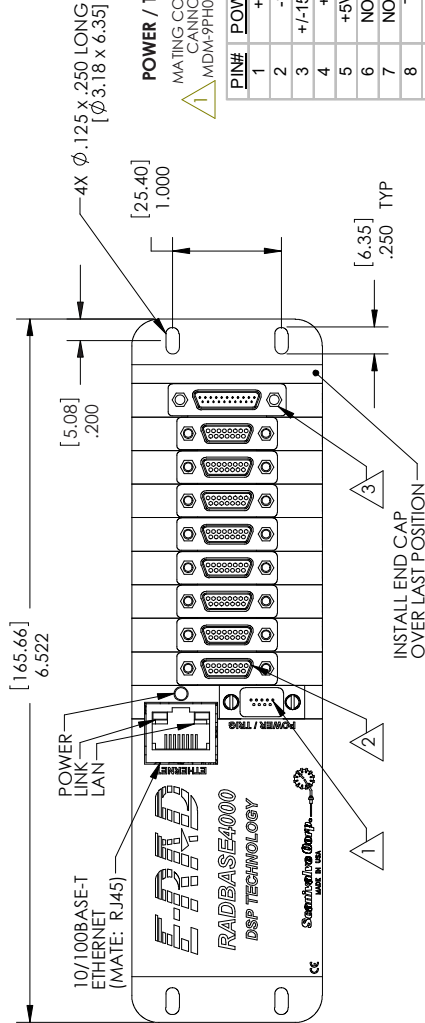

POWER / TRIGGER
 MATING CONNECTOR CANNON PN: MDM-9PH003K-A174

| PIN# | POWER/TRIG |
|------|--------------|
| 1 | +15VDC |
| 2 | -15VDC |
| 3 | +/-15VDC RTN |
| 4 | +5VDC |
| 5 | +5VDC RTN |
| 6 | NOT USED |
| 7 | -15V |
| 8 | TRIG+ |
| 9 | TRIG- |

A/D SECTION
 MATING CONNECTOR CANNON PN: MDM-15SH003K

| PIN# | A/D SECTION |
|------|-------------|
| 1 | ADDRESS 0 |
| 2 | ADDRESS 1 |
| 3 | ADDRESS 2 |
| 4 | ADDRESS 3 |
| 5 | ADDRESS 4 |
| 6 | +15V |
| 7 | -15V |
| 8 | +TEMP |
| 9 | -TEMP |
| 10 | GND |
| 11 | +OUT |
| 12 | -OUT |
| 13 | NOT USED |
| 14 | ADDRESS 5 |
| 15 | NOT USED |

RDS SECTION
 MATING CONNECTOR CANNON PN: MDM-21PH003L-A174

| PIN# | RDS SECTION |
|------|-------------|
| 1 | SW1-A |
| 2 | SW2-A |
| 3 | SW3-A |
| 4 | SW4-A |
| 5 | SW5-A |
| 6 | SW6-A |
| 7 | SW7-A |
| 8 | SW8-A |
| 9 | NC |
| 10 | NC |
| 11 | NC |
| 12 | SW1-B |
| 13 | SW2-B |
| 14 | SW3-B |
| 15 | SW4-B |
| 16 | SW5-B |
| 17 | SW6-B |
| 18 | SW7-B |
| 19 | SW8-B |

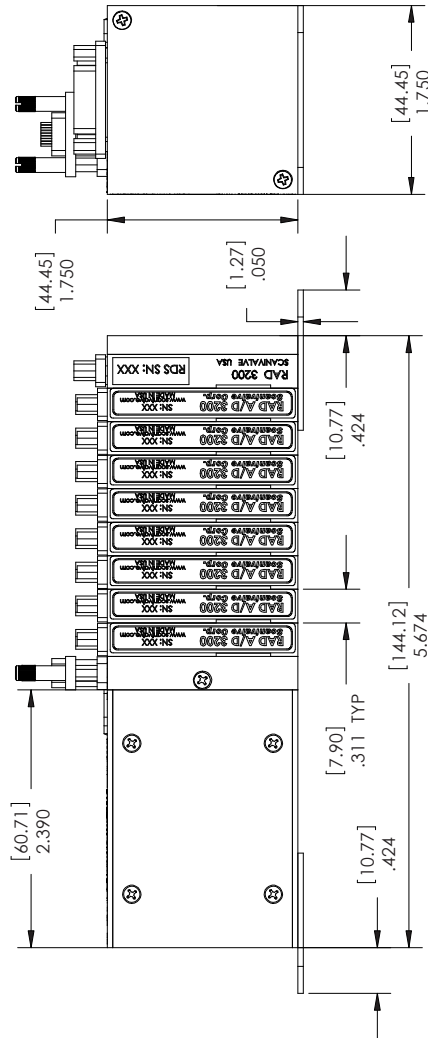

Scanivalve Corp.
 LIBERTY LAKE, WA

UNLESS OTHERWISE SPECIFIED:
 DIMENSIONS ARE IN INCHES
 TOLERANCES:
 TWO PLACE DECIMAL ± 0.05
 THREE PLACE DECIMAL ± 0.005
 SHEETMETAL PARTS ± 0.10

| NAME | DATE |
|------|---------|
| BCB | 2-16-10 |
| BCB | 2-16-10 |
| BCB | 2-16-10 |
| BCB | 2-16-10 |

TITLE:
 RADBASE4000 (ERAD)
 OUTLINE DRAWING

VALUED CUSTOMER:
 N/A

CUSTOMER APPROVAL:
 DATE: _____

SIZE DWG. NO. 81243
 REV 00

DO NOT SCALE DRAWING
 CAD: SOLIDWORKS 2009
 SCALE: 1:1 EROF:
 SHEET 1 OF 1

SECTION 2: INTRODUCTION

ERAD4000 GENERAL DESCRIPTION

The ERAD4000 is a stand alone data system. It is designed to permit all Scanivalve Corp Cable Service Modules to be utilized in an Ethernet system. This includes all MPS4164, ZOC33, ZOC23, ZOC22, ZOCEIM and ZOC17 modules. Each ERAD4000 can accept up to 8 Analog to Digital Modules. Each A/D module can interface to one MPS or ZOC Analog Pressure Scanner. A ZOC Analog Pressure Scanner may have 8 to 64 inputs. A MPS Analog Pressure Scanner may have 64 inputs.

The ERAD4000 is designed for use in applications where space is at a premium or where portability is important. A ERAD4000 may be configured with as few as one(1), or as many as eight(8) A/D's, depending upon the test requirements. When a MPS or ZOC module is to be used with a ERAD4000, it must have an RTD installed so a three dimensional Pressure/Temperature characterization table can be generated. These coefficients can then be downloaded into the ERAD4000 and used to generate Engineering Unit data. RAD to MPS or ZOC module cables are limited to 50 feet(15 meters) for heavy duty cables, or 15 feet(4.6 meters) for normal cables. For optimum results, and to fully utilize the capabilities of the ERAD4000, the MPS or ZOC module should also have a TEDS chip installed. This chip contains a unique serial number and all of the information regarding the module. At power up, or when commanded, the ERAD4000 will output this information to the Host computer.

The ERAD4000 must be connected, via Ethernet to a Host Computer running Windows XP, Windows Vista, or Windows 7. For more information on specific applications, please contact Scanivalve Corp, Product Support Department.

ENVIRONMENTAL CONSIDERATIONS

The ERAD4000 modules are constructed with a rugged, corrosion resistant anodized aluminum case. This case is designed to withstand normal industrial, flight test, educational, wind tunnel or similar applications. The case is splash resistant, but not water proof. If any moisture gets spilled or splashed on the ERAD module, wipe it dry immediately to prevent damage to the module. The ERAD4000 should not be mounted outdoors.

The ERAD4000 includes a mounting plate that can be installed on the bottom of the module which allows the ERAD4000 to be mounted in any orientation.

The ERAD4000 module should not be mounted in a location where it may be subjected to extreme temperature shifts or ambient temperatures outside of the specified operating range of the module. Keep in mind that the internal temperature of the module will run warmer than ambient temperature in most cases.



FIGURE 2.1- ERAD4000 WITH 1 A/D

ERAD4000 POWER REQUIREMENTS

The ERAD4000 requires three well regulated voltages for proper operation, + 15 Vdc, -15 Vdc and + 5 Vdc. Use of the Scanivalve RPM1000 Power Supply is recommended. The + 5 Vdc input is the most critical of the three voltages. When very small gauge wires are used in the power cables, this voltage could have significant voltage drops. The voltage drop will be excessive when the total resistance in the power lines exceed 0.25 ohms. It is recommended that Sense lines be used with this voltage to eliminate the possibility of voltage losses.

NOTE: The power to the ERAD4000 must be removed before connecting or disconnecting ZOC or MPS Modules, A/D Modules, or RDS Modules. If the power is not off when modifying the ERAD configuration, the ERAD4000 and the system components may be damaged.

The connector to the RPM1000 is a Bendix PTO6A-16-8P-SR. The connection to the ERAD4000 is a Cannon MDM-9PSB connector.

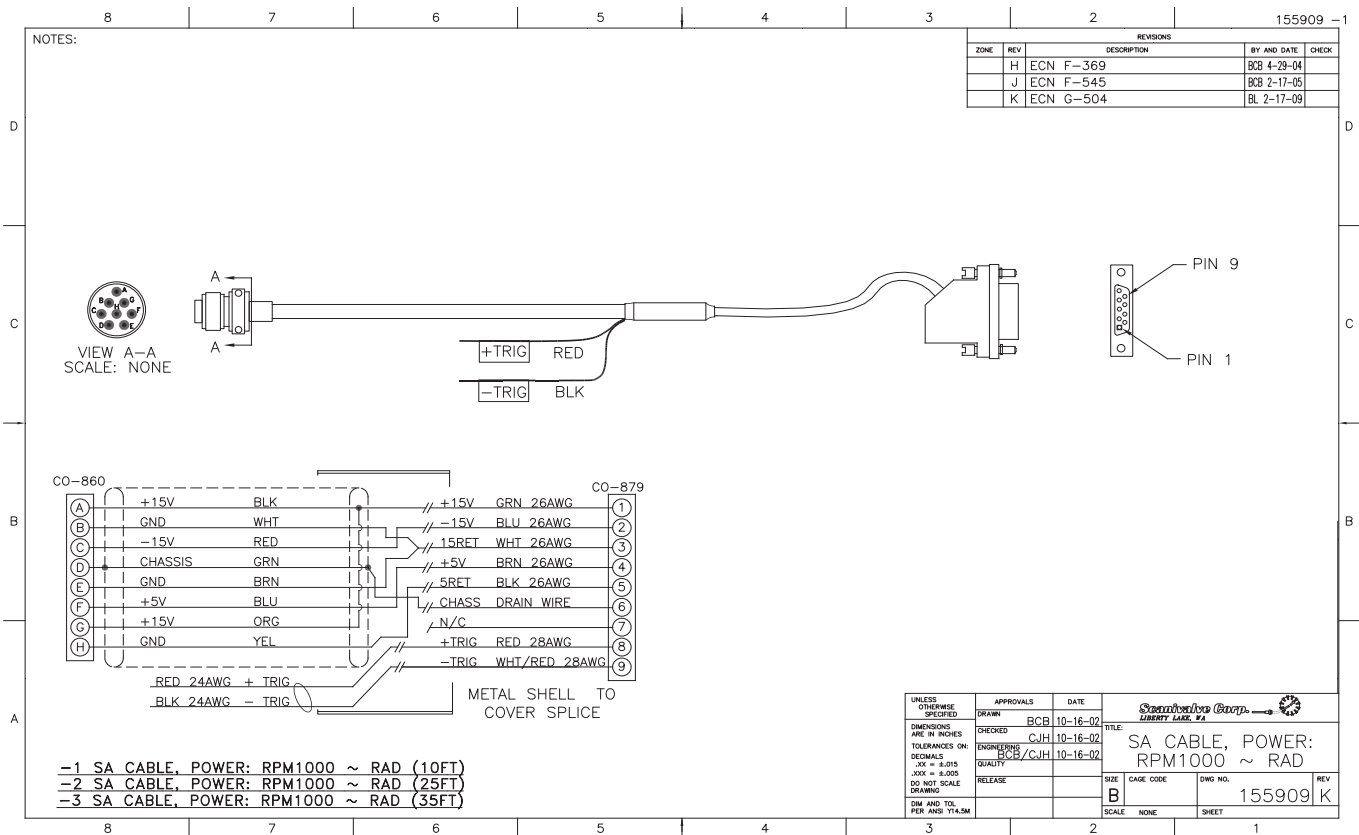

FIGURE 2.2- ERAD4000 TO RPM1000 POWER CABLE WIRING

ETHERNET CONNECTION

A ERAD4000 has one Ethernet connection, 10/100Base-T with MDIX auto-crossing. The Ethernet subsystem supports IEEE 802.3 Ethernet standards for 10BaseT and 100BaseT. The subsystem will auto-negotiate the data rate. The Ethernet connection is a RJ45 jack. This subsystem also supports PC97, PC98, and Net PC standards.

The ERAD4000 will not support multiple Ethernet connections. If a second Ethernet connection is made to the ERAD4000, the first connection will be dropped. For more information on the Ethernet connection including the default IP address and instructions on changing the IP address, see "IP Address" on page 17.

"Figure 2.3 - Ethernet RJ45 Plug and Jack" shows the RJ45 jack, and plug and wiring. The Ethernet cable used should not be longer than 328 feet (100 meters).

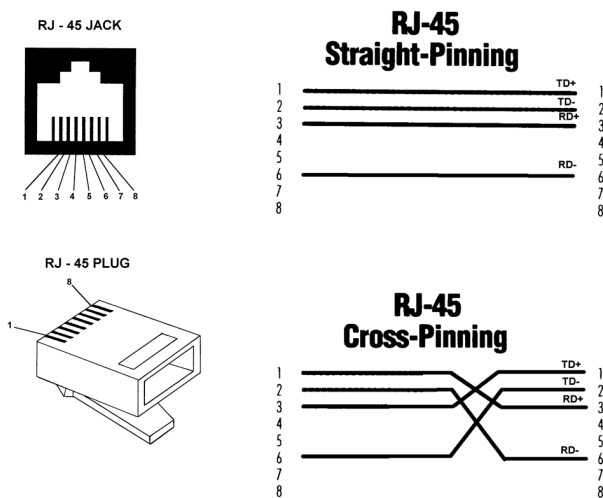

FIGURE 2.3- ETHERNET RJ45 PLUG AND JACK

CONFIGURATION CONNECTION

The ERAD4000 has RS232 Serial Input/Output capabilities. The Serial connection may be used to verify IP addresses, modify Configuration Variables, and other setup functions. The Serial connection may not be used to scan or acquire data.

The communication setup is 9600 BAUD, 8 data bits, 1 stop bit, No Parity, No Flow Control.

The RS232 connector may be accessed by removing the end plate of the ERAD4000 and connecting a special cable, Scanco part number 156023-1. This cable is provided with the ERAD4000 as an accessory. A Null modem RS232 cable must be used to connect this cable to a host computer. For more information on accessing the RS232 input connector "Operation in Bootloader Mode" on page 22.

"Figure 2.4 - Configuration Cable Wiring" shows the RS232 jack, plug and wiring.

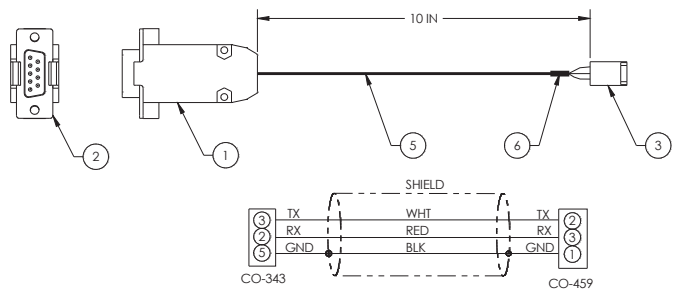

FIGURE 2.4- CONFIGURATION CABLE WIRING

DIGITAL I/O CONNECTIONS VIA RDS3200

The RDS, Remote Digital Switch, contains eight(8), software controlled and optically isolated, switches. The switches are controlled by the Digital Output Configuration Variables or the DOUT Commands in the RAD software. For more information on the Digital Outputs, refer to “Section 4: Software” on page 24.

Each switch is rated for 1 A at 60 V. The Voltage may be AC or DC. If the switches will be used to switch power, the power must be supplied by the user.

The RDS has a four position DIP switch that is used to set the address, or position in the ERAD4000. The RDS must always be the last unit in the system. The A/D modules may be installed in positions 1 through 8 (binary 0 - 7). An RDS is always position 9(binary 8) or higher. The RAD may accept up to 8 RDS Modules which must be programmed as positions 9 through 16 (binary 8 to 15) respectively. A truth table for the RDS DIP switch setting is shown in the table.

The first RDS must be installed in location 9. The DOUT commands will not function unless the first RDS is in that location. If an RDS is not installed correctly, an error will be reported at boot up. A mating connector, Cannon MDM-21PH003L-A174, is supplied with each RDS. The pinout of the RDS is shown in Figure 2.6.

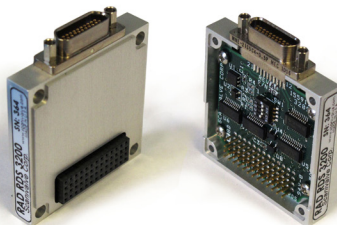

FIGURE 2.5- RDS3200

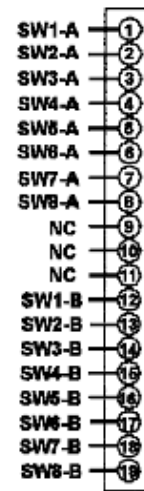

FIGURE 2.6- RDS3200 PINOUT

| RDS3200 DIP Switch Settings | | | | | |
|-----------------------------|--------|-----|-----|-----|-----|
| Position | Chnls. | SW1 | SW2 | SW3 | SW4 |
| 9 | 1-8 | ON | ON | ON | OFF |
| 10 | 9-16 | OFF | ON | ON | OFF |
| 11 | 17-24 | ON | OFF | ON | OFF |
| 12 | 25-32 | OFF | OFF | ON | OFF |
| 13 | 33-40 | ON | ON | OFF | OFF |
| 14 | 41-48 | OFF | ON | OFF | OFF |
| 15 | 49-56 | ON | OFF | OFF | OFF |
| 16 | 57-64 | OFF | OFF | OFF | OFF |

ZOC INPUT CONNECTIONS

Each ERAD4000 is designed to accept inputs from up to 8 MPS4164, ZOCEIM, ZOC 17, 22, 23 or 33 modules or any combination. Each MPS or ZOC module may have up to 64 pressure inputs. The MPS or ZOC modules must have an RTD installed so the ERAD4000 can measure the temperature of the module.

The length of the ERAD4000 to analog modules, or TCU cable is critical to the functionality of the system. This cable cannot exceed 50 feet (15 meters) for heavy duty cables or 15 feet (4.5 meters) for normal cables. The input connectors are Cannon MDM-15PBSP. The mating connector (cable connector) is a Cannon MDM-15SH003K.

“Figure 2.7- ERAD4000 to ZOC Cable” shows the typical input wiring for a MPS or ZOC module. “Figure 2.8- ERAD4000 to ZOCTCU Cable” shows the typical wiring for a MPS or ZOC module installed in a Thermal Control Unit.



CAUTION! Connecting or disconnecting ZOC modules with the ERAD4000 powered up will cause permanent damage to both the ERAD4000 and the ZOC module(s).

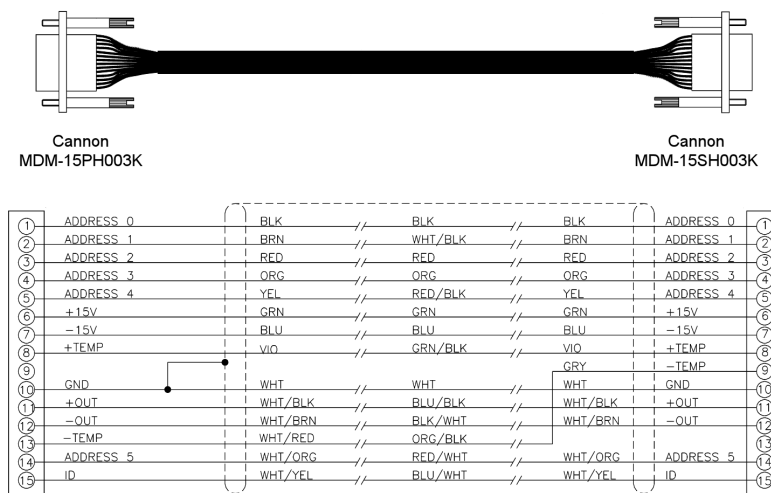

FIGURE 2.7- ERAD4000 TO ZOC CABLE

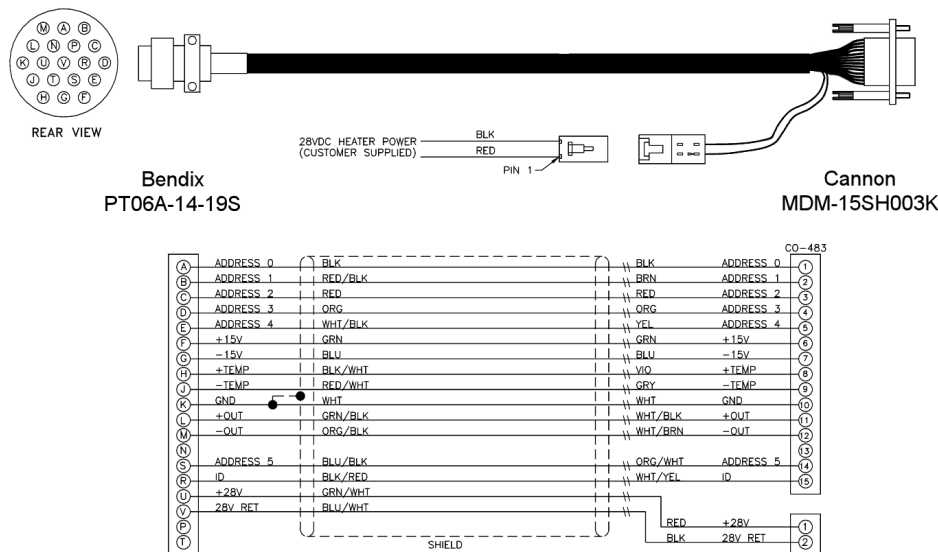

FIGURE 2.8- ERAD4000 TO ZOCTCU CABLE

RAD A/D 3200- REMOTE A/D MODULES

Each ERAD4000 may have up to 8, 16-bit pressure A/D modules. Each A/D module has an ID chip installed. The ID chip identifies the module by type, location and serial number. Each module can be characterized to correct for zero and gain errors, thus minimizing system errors. This information is contained in the ID chip. When the Rad4000.hex program is started, the software identifies each A/D and maps the correction coefficients into memory. This data is used during the conversion of the analog inputs to an engineering unit to minimize errors from the A/D's.

The A/D modules have a DIP switch used to identify the position of the A/D. This switch must be set by the user when the A/D is installed. The A/D module's DIP switches must be set for a position between 1 and 8 (binary 0 - 7). The actual physical position of the modules is not important. A truth table showing the DIP switch settings is shown below.

| Position | SW1 | SW2 | SW3 | SW4 |
|----------|-----|-----|-----|-----|
| 1 | ON | ON | ON | ON |
| 2 | OFF | ON | ON | ON |
| 3 | ON | OFF | ON | ON |
| 4 | OFF | OFF | ON | ON |
| 5 | ON | ON | OFF | ON |
| 6 | OFF | ON | OFF | ON |
| 7 | ON | OFF | OFF | ON |
| 8 | OFF | OFF | OFF | ON |

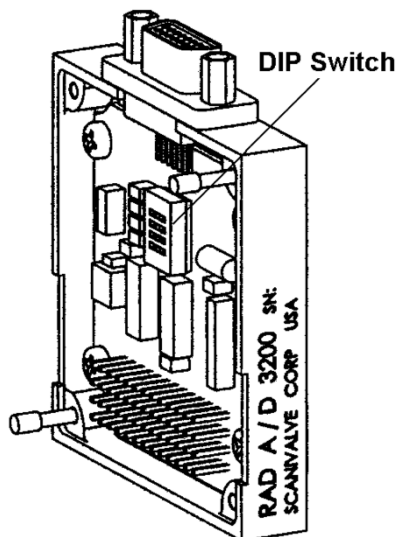

FIGURE 2.9- A/D 3200

SOFTWARE

When the ERAD4000 is mounted and the power requirements are met, the unit is ready to be configured for use. All configuration variables must be set using Rad4000.hex. A user may connect a computer to the ERAD4000 and communicate by one of several associated programs:

Ethernet

TelNet - A program furnished with Windows 95 and 98. This permits a network connection to the ERAD4000. A TelNet session is described later in this manual

HyperTerminal - A terminal program furnished with Windows NT, 2000 and XP. This program may be configured for Ethernet or Serial Communications.

ERAD LabVIEW VI- Drivers written by Scanivalve Corp. are available for use with LabVIEW versions 5.0 and higher.

ScanTel - A free program created by Scanivalve similar to HyperTerminal. ScanTel can be used to configure the ERAD4000 and acquire data in both ASCII and Binary format.

RS232

The 'Configuration' port offers an RS232 serial connection to the ERAD4000. This connection can be used to configure the module but does not offer the ability to collect data.

RAD4000.HEX

The ERAD executable program controls the operation of the ERAD4000, A/D modules and RDS module. This software is installed on a MicroSD card installed in the ERAD4000. At bootup the software is read into RAM and started.

SECTION 3: OPERATION

This section contains information and procedures required for the proper operation of ERAD4000 series modules.

The entire boot process requires approximately 1 minute, depending on the number of ZOC modules connected. When the ERAD4000 is ready to accept commands a prompt symbol will be transmitted to the host computer.

All operation and configuration of the ERAD4000 is through Ethernet connection.

UNPACK & INVENTORY

When you first unpack the ERAD4000 module, begin by inspecting and inventorying the contents of the package. If any visible damage is immediately noticed or if any contents are missing, contact Scanivalve before proceeding. As a minimum, ERAD4000 modules are shipped with the following contents:

1. ERAD4000 module
2. ERAD4000 resource CD
3. Configuration cable connector

MOUNTING

The ERAD4000 comes with a mounting plate attached to the bottom. This accepts mounting hardware up to 1/8"(3.18mm) in diameter. The ERAD4000 can be mounted in any orientation. Ensure that the ERAD module is mounted in an environment that conforms to the requirements described in "Environment Specifications" on page 9.

WARM-UP

After applying power to the ERAD4000 and attached ZOC modules, a minimum of 30 minutes before collecting data is required to allow the module temperature to become stable. It is recommended that if time allows, the warm-up period should be extended to one hour for most applications.

COMMUNICATIONS

The ERAD4000 module is designed primarily for Ethernet communications. This provides a means to configure the ERAD4000 module as well as scan and collect data from the module.

A 'Configuration' port is also provided. The 'Configuration' port is a serial RS-232 connection designed to be used to configure the module and provide emergency

communications.

Several important variables can be configured through the serial port, but possibly the most important is the Ethernet IP address. The only way to communicate with the module if the IP address is not known is through the 'Configuration' port.

CONFIGURATION PORT

Every ERAD4000 module has an RS-232 serial output. It is available through a connector inside of the module. To access this connector see "Operation in Bootloader Mode" on page 22. All ERAD4000 modules are shipped with a mating connector (DE-9S) that can be used to fabricate a Configuration cable. Alternately, a Serial Configuration cable can be ordered from Scanivalve using the Scanivalve part number 156023-1.

The wiring diagram for the Configuration cable is shown in "Configuration Connection" on page 12

Settings for establishing a serial connection to the ERAD4000 module are as follows:

- Bits per second: 9600 BAUD
- Data bits: 8
- Parity: none
- Stop bits: 1
- Flow control: None

ETHERNET COMMUNICATIONS

The primary means of communication with the ERAD4000 is the 10Base-T Ethernet port. Shielded Category 5 cable or better is recommended for all Ethernet connections. The ERAD4000 features MDIX auto-crossing support. No matter what the network architecture being used is, the ERAD4000 can be connected with either a straight through (pin to pin) cable or a crossed cable.

The ERAD4000 module does not support multiple Ethernet connections. However, if a second Ethernet connection is made to a ERAD4000, the current connection will be dropped for the new connection.

IP ADDRESS

Before an Ethernet connection can be established the IP address need to be configured. In order to be compatible, the IP address of the module and host computer must share the first two octets. The third and fourth octets of the IP address is variable, although it is recommended that the third octet also be shared between the host computer and the module.

Example of matching the first three octets (recommended):

Host computer: 191.30.40.100

ERAD module: 191.30.40.125

Example of matching the first two octets:

Host computer: 191.30.1.100

ERAD module: 191.30.40.125

The IP address of a Windows host computer can be changed under:

Control Panel -> Network Connections -> Local Area Network -> Properties -> Internet Protocol (TCP/IP) -> Properties.

All ERAD4000 modules are shipped with a default IP address in the following format:

191.30.40.XXX

(where XXX = the last three digits of the module serial number)

The IP Address can be modified by changing the value of IPADD. This variable is in the IP Group of configuration variables. IPADD may be set using the either the Configuration or Ethernet connections. The new address will not be effective until a SAVEIP command has been issued and power has been cycled. For more information on the IPADDR variable, see "IPADDR" on page 90.

CLIENT/HOST OPTIONS

Once the module has been connected and the IP address has been configured, communications can be established with the ERAD module. Communications can be made through several software packages including:

- PC - TCP/IP
- PC - UDP
- PC - ScanTel (Scanivalve PN: 155406-01)
- PC - LabVIEW Configuration Utility (Scanivalve PN: 155384-01)
- PC - LabVIEW Development Kit (Scanivalve PN: 155385-01)
- PC - Windows HyperTerminal

PC - TCP/IP

The user may write their own TCP/IP interface using the software specification portion of this manual. This interface should allow the user to:

- Issue commands to any or all ERAD modules on the network.
- Display returned information or scan data from the ERAD module(s).
- Write returned information or scan data to the client/host in TCP/IP format.

PC - UDP

The user may write their own UDP interface using the software specification portion of this manual. This interface should allow the user to:

- Issue commands to any or all ERAD modules on the network.
- Display returned information or scan data from the ERAD module(s).
- Write returned information or scan data to the client/host in UDP format (no handshaking).

PC - SCANTEL

ScanTel is a free communications utility designed by Scanivalve to communicate with Scanivalve products including ERAD4000 modules. It is a text based, command line program that allows users to connect to a single ERAD module and modify the configuration variables, upload or download coefficients and collect data in both TCP/IP and UDP format.

PC - LABVIEW CONFIGURATION UTILITY

The Scanivalve LabVIEW Configuration Utility is a software package that offers a very intuitive and simple way to connect to and modify all of the ERAD4000's configuration variables. It also allows the user the ability to upload a configuration file and scan and collect data. The scanning and data collection is limited to 5Hz due to the graphic nature of the program. The LabVIEW Configuration Utility is based on a LabVIEW 2009 runtime which is included with the installation disk.

PC - LABVIEW DEVELOPMENT KIT

The Scanivalve LabVIEW Development Kit is for users desiring to customize a LabVIEW driver for ERAD4000 systems. The Development Kit is compatible with LabVIEW 8.2, 8.6 and 2009. The LabVIEW Configuration Utility is included with the Development Kit.

PC - HYPERTERMINAL

HyperTerminal is a Windows program included as part of Windows 2000, XP and Vista Operating Systems. This program permits a user to connect to a single ERAD module, modify the configuration variables, upload or download coefficients and collect data. HyperTerminal provides a means for both Serial RS-232 and Ethernet connections. It is a text based command line program.

DIP SWITCH SETTINGS

The processor board has 4 DIP switches that affect the operation of the software. These switches are only read at power up. Changes to the dip switches are not effective until the power is cycled.

SW1 - When this switch is on, the application automatically boots on power up. When this switch is off, the ERAD4000 remains in the boot loader mode. The default is on.

SW2 - When this switch is on, the boot loader will run in the debug mode. Debug output is directed to the serial port. Default is off.

SW3 - Spare.

SW4 - Spare.

“Figure 3.1 - DIP Switch Location” shows the ERAD4000 cover removed and the location of the DIP switches on the processor board.

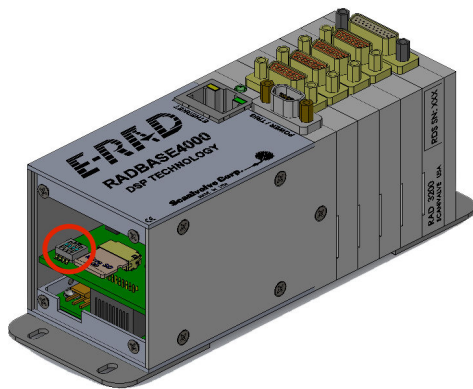

FIGURE 3.1 - DIP SWITCH LOCATION

MODULES

The ERAD4000 will support up to eight modules. The ERAD4000 supports any ZOCEIM, ZOC 17, 22, 23 or 33 module with an RTD. The ZOC modules must have an RTD so the ERAD000 can properly determine the temperature of the module and ultimately the coefficients to be used.

Modules should only be connected and disconnected with power removed from the ERAD4000. After the modules are connected, power may be applied. Configuration of the ERAD4000 may be checked during warm up. At this time, if calibration coefficients have been installed, it is very important to verify that the modules are connected to the proper inputs. Otherwise, data may be invalid.

DSP BOOT LOADER

The Scanivalve DSP Boot Loader permits a user to upload the ERAD4000 application via FTP. The boot loader runs the FTP server. It has been tested on Mozilla ‘FileZilla’ and Windows Explorer drag and drop. Any additional file transfer protocols or additional FTP client support modification will be made solely to the application. For more information on Bootloader Operation, refer to “Operation in Bootloader Mode” on page 22.

FTP

The FTP server supports the following FTP commands prior to login:

USER - Allows the user to enter the user’s name. Anonymous is allowed.

PASS - Allows the user to enter the password.

QUIT - Disconnects from the FTP server.

The FTP server supports the following FTP commands after login:

RETR - Initiates a file transfer from the ERAD4000 to the host.

STOR - Initiates a file transfer from the host to the ERAD4000

PASV - Sets up data port so client can connect to server’s port.

LIST - Returns a directory listing of the files stored on the ERAD4000

SIZE - Returns the size in bytes of the file.

DELE - Deletes the file.

NOOP - No operation. Mostly used by the client as an “are you still there” command.

ASCII format transfers are the only supported transfer type. Passive data connections are the only supported connection type. This allows data to be transferred without the server initiating a connection to the client. This could cause firewall problems.

BOOT LOADER AND APPLICATION FILE SYSTEM

Filenames are limited to the 8.3 format with no spaces allowed. Only one drive is supported. Because the ERAD4000 does not have a time and date clock, all files created will have a date of Aug 8, 2008. No subdirectories are supported, however, if a file path is included in the file specification only the file name portion is used. The file will be written in the root directory of the drive. The disk drive will hold a maximum of 1024 files, or 2GB of data.

HOST COMMUNICATION

Commands are issued to the ERAD4000 and response is returned via either the Ethernet port or the Configuration port. The boot loader returns the command information to the host that it received its command. That is, when the command is received from the network it is returned to the network. When it is received from the serial port, it is returned to the serial port. The SCAN function is not supported in Configuration/Serial operation.

The network supports TCP/IP connection using Telnet or HyperTerminal.

COMMANDS

When a command is complete, the prompt character, the greater than character ">", is output preceded by a carriage return and line feed.

The commands listed below are supported by the boot loader and the executable program, unless otherwise noted. They may be viewed and modified in the ERAD4000 executable program.

VER - Returns the version of the Boot Loader. NOTE:

This command is specific to the boot loader only. It should not be confused with the VER command in the application.

FDISK - Formats the SD Flash to all 0's. NOTE: This command is available in the boot loader only.

LIST IP - Returns the settings of the IP group. This command is explained in detail in the software manual.

SET <parameter> - Set the indicated parameter.

IPADD <IP address> - Sets the IP address of the ERAD4000. If the IPADD is changed, the power must be cycled to take effect.

SUBNET <mask> - Sets the subnet address of the ERAD4000. If the SUBNET is changed, the power must be cycled to take effect.

MAC <MAC address> - Sets the MAC address for the ERAD4000. If the MAC is changed, the power must be cycled to take effect.

LOGIN <user name> - Sets the user name for FTP login.

PASSWORD <password> - Sets the password associated for LOGIN.

LOGIN1 <user name> - Sets the user name 1 for FTP login.

PASSWORD1 <password> Sets the password associated for LOGIN name1.

LOGINNAS <name> - Sets the name for login to the NAS. The boot loader does not access the NAS (Network Attached Storage) device. This is a place holder in this group for compatibility with the IP group in the application.

PASSWORDNAS <password> - Sets the password

associated with LOGINNAS name.

IPADDNAS <IP address> -Set the IP address of the NAS
 NASAPP <application file name> - Sets the file name of the application to run. This is the file name that is used when automatically running the application from the boot loader. It is also the file name used when using the RUN command. If this file is not found, an error is returned.

SAVE [<file name>] - Saves the configuration variables to the working directory. When an optional file name is entered, it saves the IP group settings to that file name.

TYPE <file name> - Types the contents of the file name.

LOAD <file name> - Loads the file name into the LIST IP configuration variables.

DIR - Lists the file on the SD card.

DEL<file name> - Deletes the file name.

DIP - Reads and shows the settings of the DIP switches.

The following is returned: "DIP settings Auto Run Application 0 Debug 0 No Serial Host 0 Spare 0" where 1 indicates on, 0 indicates off. NOTE: This command is available in the boot loader only.

RUN - Runs the application named in the SET APP setting. NOTE: This command is available in the boot loader only.

NETWORK ATTACHED STORAGE (NAS)**OPERATION**

When the variable: ENNAS is set to 1 or 2, all ASCII or BINARY data is directed to the NAS via FTP. Binary files will have the extension: .BIN. ASCII files will have the extension: .TXT.

The setting of ENNAS will determine the construction of the file name.

When ENNAS is set to 1, a sequence number is used to construct the file name.

For Binary (BIN = 1), the file name will be the file name prefix as set by the variable: FILENAS and a sequence number set by the software. The format is:

<file name prefix>_SSSS.BIN

For ASCII (BIN = 0), the file name will be the file name prefix as set by the variable: FILENAS and a sequence number set by the software. The format is:

<file name prefix>_SSSS.TXT

The sequence number is maintained in the ERAD4000 and saved to a file named: SSN.CFG. The save to SSN.CFG is automatic and not part of the SAVE command group. This file is maintained on the Micro SD. If this file is not found the sequence will start at 0000.

NAS SETUP FOR USE WITH A ERAD4000

When a NAS is used with a ERAD4000, it must be set up as a FTP Server. A user must consult the documentation for the NAS being used to insure proper operation.

LOCAL HOST COMPUTER SETUP AS A NAS

A Local/Host computer, such as a Laptop, may be used as a NAS for high speed data storage. In order for the data to be transferred, the computer must be set up as a FTP Server. FTP Server software must be set up and running before a SCAN command is issued.

NETWORK TIME PROTOCOL

The ERAD4000 can take advantage of a Network Time Protocol (NTP) server. Information on the configuration variables for the NTP setup can be found in “Network Attached Storage Configuration Variables (Group NAS)” on page 93.

CALIBRATION

All modules that will be used with a ERAD4000 must be fitted with an RTD so the ERAD4000 can determine the temperature of the module. This is critical to allow a user to achieve the best possible accuracy in a system. A module, once calibrated, may be used in any position in a ERAD4000 system. It may even be moved to a different ERAD4000 with no loss in accuracy.

The key to this capability is the module profile (coefficient) files and the module list. The module profile files (mpf files) contain module setup information and calibration coefficients. Each module should have its own unique MPF file, identified as xxxx.mpf: where xxxx is the serial number of the module. The module list contains a listing of module serial numbers versus the input position.

At boot up, the ERAD4000 software looks for the file: sn.gpf. This file contains the module profile list. The software reads the file. If an input position has a number greater than 0 assigned to it, the software looks for the corresponding MPF file in the ERAD4000 folder on the Hard Disk and maps the setup and coefficients into the ERAD4000 RAM memory. If an MPF file cannot be found, default configuration information is entered into memory.

ERAD4000 MODULE COEFFICIENT INSTALLATION

When a ERAD4000 and modules are purchased as a system, the module coefficients will be stored on the MicroSD card (SN 197 and older), or on a flash memory chip. A backup CD with the MPF files will be included with the system. When new modules are added to a system, or when a coefficient file must be updated, the files may be uploaded using the “ERAD4000 Calibration Coefficient Installation (Windows XP

& 7)” on page 22.

EXTERNAL TRIGGER

The ERAD4000 series modules may be triggered externally by a hardware or software trigger. The settings of ADTRIG and SCANTRIG determine the function of the Digital Inputs as related to scan and frame triggers. Note that Timestamp will not return a correct value with external triggering. The ADTRIG and the SCANTRIG variables are in the SCAN Variables Group. More information can be found under “Scan Group Configuration Variables (Group G1 through G8)” on page 79.

HARDWARE TRIGGER

The external trigger input is optically isolated to prevent grounding problems. It is a TTL level, edge sensing device. It requires a minimum signal of 9Vdc @ 6.5 mA. It may accept voltages as high as 15 Vdc. The external trigger will only be active if SCANTRIG or ADTRIG is set to 1. If SCANTRIG is set to 1, a hardware trigger will initiate the SCAN function. If ADTRIG is set to 1, the module enters the SCAN mode and waits for a trigger when a SCAN command is issued by the Client/host, The module will return an averaged frame of data for each trigger pulse received. This will continue until the FPS variable (Frames per Scan) value is met, or until a STOP command is issued.

SOFTWARE TRIGGER

The software trigger will only be active if ADTRIG is set to 1. When a SCAN command is issued by the Client/host, the module will enter the SCAN mode and wait for a trigger. An averaged frame of data will be output as soon as a <TAB> character (9 HEX or Control I) is received. Data will be output with each successive trigger command until the FPS variable (Frames per Scan) value is met, or until a STOP command is issued.

SPECIAL PROCEDURES

This section contains the procedures to update the firmware, add calibration coefficients to the Micro SD card, and solutions to long cable operation. The ERAD4000 should be in the READY mode while these changes are being made. This will have no effect on the operation. The procedures described in this section are written for use in a Windows operating system.

The firmware and coefficient procedures that follow may not function correctly if Window Internet Explorer is not set up correctly. A user should verify these settings before attempting these procedures.

INTERNET EXPLORER SETUP

1. Open Internet Explorer
2. Click on Tools
3. Select Internet Options from the menu.

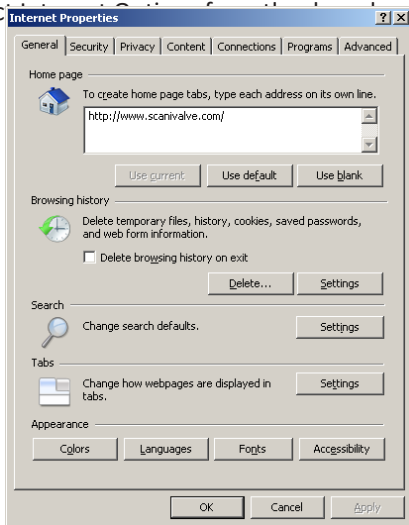

The Internet Options window will open.

4. Click on the Advanced Tab to show the Advanced Settings.
5. Scroll down to the heading marked "Browsing"
6. Make sure that the line "Enable FTP Folder View (Outside of Internet Explorer)" is checked. If this is not enabled, Internet explorer will block FTP file transfers.

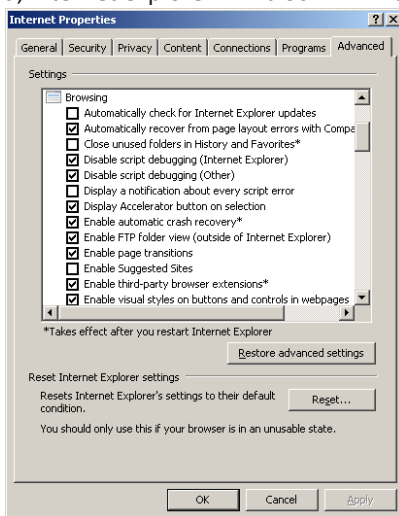

7. Click OK to accept the settings.

ERAD4000 FIRMWARE INSTALLATION (WINDOWS XP & 7)

NOTE: Some firewalls may block file transfers. We recommend that firewalls be shut down for the procedures in this section.

1. Connect a host computer to the Ethernet port.
2. Install the disk with the new or updated firmware (Rad4000.hex).
3. Open My Computer
4. In the Address Bar, type: ftp://<IPAddress><Enter>
Where:<IPAddress> is the IP Address of the ERAD4000.
5. The host computer should connect, if the connection is successful, the contents of the ERAD4000 Micro SD Card will be displayed in a folder format.

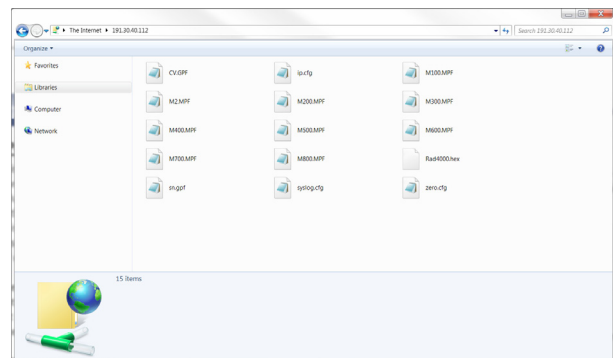

6. Highlight the existing ERAD4000.hex file. Right click on it, and select Delete. A window will open to confirm the delete. Click Yes to delete the file.

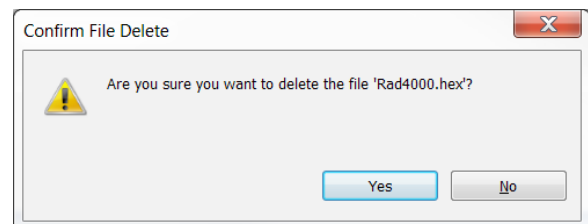

7. Open Windows Explorer in another window. Find the directory where the new ERAD4000.hex file is stored. Highlight the file and:

Click: Edit

Click: Copy

8. Select the ERAD4000 window and:

Click: Edit

Click: Paste

The file will be copied to the ERAD4000. A progress window will provide progress information.

9. When the copy function is complete, the ERAD4000 window will show the new file. The time and date will show the Time and Date of the transfer. This is the only time this date will be shown. All files on the ERAD4000 will show the same date and time after a reboot or power cycle.

10. Cycle the power or issue a reboot command to complete the process.

ERAD4000 CALIBRATION COEFFICIENT INSTALLATION (WINDOWS XP & 7)

NOTE: Some firewalls may block file transfers. We recommend that firewalls be shut down for the procedures in this section.

1. Connect a host computer to the Ethernet port.
2. Open My Computer
3. In the Address Bar, type:
ftp://<IPAddress><Enter>

Where: <IPAddress> is the IP Address of the ERAD4000.

4. The host computer should connect. If the connection is successful, the contents of the ERAD4000 Micro SD Card will be displayed in a folder format.

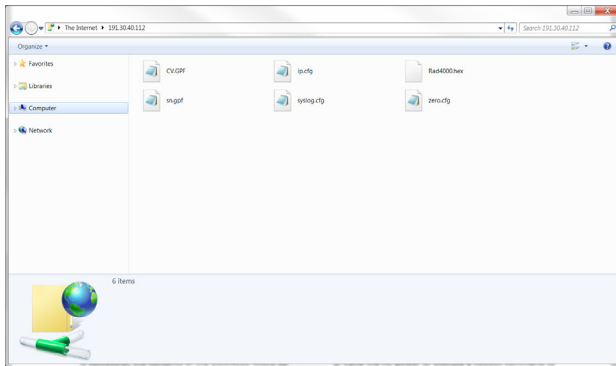

5. Open Windows Explorer in another window. Find the directory where the MPF Files are stored. Highlight the files to be copied to the ERAD4000 and:

Click: Edit

Click: Copy

6. Select the ERAD4000 window and:

Click: Edit

Click: Paste

The files will be copied to the ERAD4000. A progress window will provide progress information.

7. When the copy is function is complete the ERAD4000 will show all the new files. The time and date will show the time and date of the transfer. This is the only time this date will be shown. All files on the ERAD4000 will show the same date and time after a reboot or power cycle.

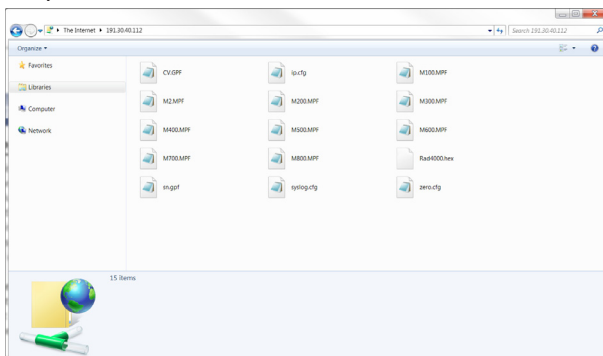

8. Cycle the AC power or execute a Reboot command to complete the process.

OPERATION IN BOOTLOADER MODE

If an ERAD4000 will not boot, or appears to have lost communications with a Host, the system may be operated in the Bootloader Mode. In this mode of operation, the application will not start. All commands may be entered by the Ethernet or Configuration ports.

This mode may be set by switching DIP Switch 1 to the off position.



CAUTION! ESD PROTECTION REQUIRED.
The proper use of grounded work surfaces and personal wrist straps are required when coming into contact with exposed circuits to prevent static discharge from damaging sensitive electronic components.

1. Ensure all power is removed from the ERAD4000. Remove the ERAD4000 front cover. Only remove the four (4) screws shown in the image below.

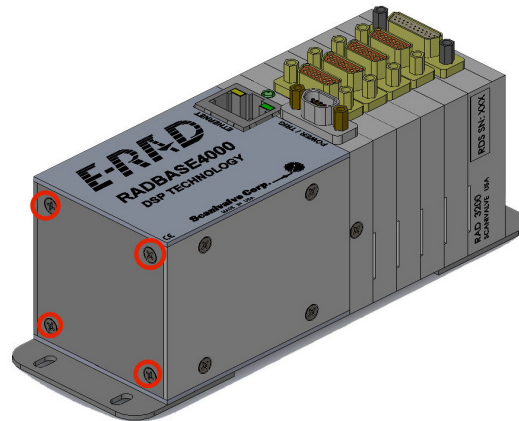

2. Remove the front cover.
3. The DIP switches (Red) are located on the processor board. Slide DIP Switch 1 so it lines up with the other switches. Switch 1 should line up with the other switches. Plug in the 3 pin RS232 Configuration Cable (Blue).

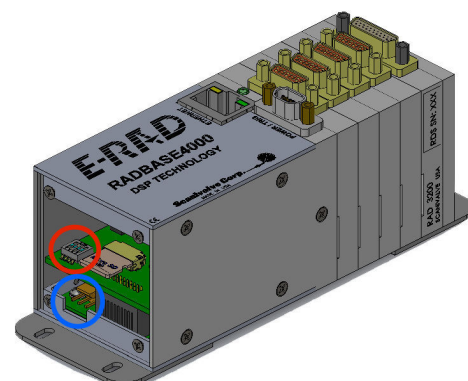

4. Re-apply power to the ERAD4000. The application will not run, but the boot loader commands can be used to troubleshoot system problems.
5. When troubleshooting is complete, remove power and reset Switch 1 to the on position. Reinstall the front cover and re-apply power.

LONG INPUT CABLE APPLICATION

For applications utilizing a cable longer than 50 ft (15 meters) the ZOC module ID Chips may not communicate with the ERAD, therefore not populating List SYS. If that is the case then the configuration must be manually set using List P in order to properly load the corresponding ZOC Module coefficients.

1. With the power OFF, configure the ERAD, MPS or ZOC modules and cables.
2. Read the saved List P information type:
LIST P<CR>
3. Load the module's MPF files into the ERAD's RAM according to the last saved "List P" in step 1.
4. Change List P to SNX 0 for all locations, where X is the module location.
 - a. Type:
SET SN1 0<CR>
 - b. Type:
SET SN2 0<CR>
5. Continue to set SNX 0 for all A/D locations. Where X is the A/D location.
6. Delete existing coefficients from RAM, type:
DELETE 0 72<CR>
7. Then, for all A/D locations with a MPS or ZOC module connected
 - a. Type:
SET SN1 XXX <CR>
Where XXXX is the the serial number of the MPS or ZOC module connected to A/D position 1.
 - b. Type:
SET SN2 XXX <CR>
Where XXXX is the the serial number of the MPS or ZOC module connected to A/D position 2.
8. Continue for all A/D locations with a MPS or ZOC module connected.

NOTE: Allow time for the ERAD to process the command before attempting to issue a new SET SNXXX command. This command can take up to 15 seconds to execute. Ensure MPF files are loaded to the ERAD for corresponding ZOC Modules. See "ERAD4000 Calibration Coefficient Installation (Windows XP & 7)" on page 22. It is best practice to set all locations to SN 0 if the modules connected to the ERAD are to be re-configured. After finishing testing, and before powering down, set all 8 locations to SN 0, then type:
SAVE

When the save is complete, power off the ERAD.

SECTION 4: SOFTWARE

The operation of each ERAD4000 is controlled by sending commands to selected units via the network. The ERAD4000 returns data or information over the same network to the requesting client/host.

ERAD4000 COMMANDS

This section describes the commands used to control the ERAD4000. The ERAD4000 software performs the following general tasks:

1. Read and filter the raw A/D counts that represent pressure and temperature.
2. Convert the pressure A/D counts to user chosen pressure units.
3. Receive and execute commands via the Ethernet or Local.
4. Output converted data, status, setup and calibration data over the Ethernet or Local outputs.

When a ERAD4000 module is in a “not ready” mode, all commands are disabled except STATUS and STOP.

COMMAND FORMAT

Each of the commands are explained with the following sections: command, syntax, arguments, description, and returns.

COMMAND lists the name of the command.

SYNTAX lists the format of the command. The following conventions are used:

BP - Boldface letters indicate command keywords and operators. Within the discussion of syntax, bold type indicates that the text must be entered exactly as shown.

expression - Words in italics indicate place holders for information you must supply, or information returned by the calibrator, such as a coefficient name or pressure data.

[/H] - Items in square brackets are optional.

, - Commas separate options, only one of the options may be used.

<CR> - Items in angle brackets are used for names of keys on a typical keyboard. The carriage-return key, sometimes marked as a bent arrow, Enter, or Return on the key board, is called <CR>.

Spaces, as used in the syntax, are entered as spaces.

DESCRIPTION describes the function of the command.

RETURNS lists the format of the information that the unit returns to the host.

A PROMPT (>) will be output when the ERAD4000 is ready to accept a command.

TCP/IP does not guarantee that packet boundaries will be maintained between a Host and a ERAD4000. Therefore, ALL commands from a Host MUST be terminated properly with one of two options using the NL configuration variable. The two options are:

CR-LF (ASCII 13 - ASCII 10) or CR (ASCII 13)

The maximum string length for commands send to the ERAD4000 is 79 characters. Any command received that is longer than 79 characters will be discarded and an error will be generated.

When a communications variable is modified (those in the LIST IP group), the ERAD4000 program must be restarted, preferably with the RESTART command, in order for the changes to take effect.

COMMAND LIST**A/D CALIBRATION**

| | |
|----------------|---|
| Command | A/D CALIBRATION |
| Command Syntax | A2DTCAL <module> <t index> <point index> <voltage> <CR> |
| Arguments | module - The A/D module being calibrated. 0 is the RADBASE, 1 to 8 indicate pressure A/D's t index - The temperature index 0 through 7 point index - the Calibration point, 0 through 15, for a t index voltage - the applied calibration voltage |
| Description | This command is used to produce the voltage correction table for a temperature compensated A/D. Although 16 points may be applied at each temperature index, a user may use as few as three points. |
| Returns | <nl> - end of line |
| Example | To calibrate a temperature compensated A/D module installed in position 1, apply a series of voltages. The entries may be as follows: A2DTCAL 1 1 0 0.0000 A2DTCAL 1 1 1 0.5000 A2DTCAL 1 1 2 1.0000 A2DTCAL 1 1 3 1.5000 A2DTCAL 1 1 4 2.0000 A2DTCAL 1 1 5 2.5000 |
| Note | This command will only generate the correction table. It does not convert the table to a set of coefficients. Coefficients are generated by the A2DTCALC command and written to the A/D module using the IDPWRITE command. |

A/D COEFFICIENT CALCULATION

| | |
|----------------|---|
| Command | A/D COEFFICIENT CALCULATION |
| Command Syntax | A2DTCALC <module> <number of temp planes> <number of points> <CR> |
| Arguments | module - The A/D module being calibrated. 0 is the RADBASE, 1 to 8 indicate pressure A/D's number of temp planes - Number of temperature planes to use during calibration number of points - Number of points taken at each temperature plane during calibration |
| Description | This command is used to produce the voltage correction coefficients for a temperature compensated A/D. Although 16 points may be applied, a user may use as few as three points. |
| Returns | <mod> <ac> <bc> <cc><nl> mod - The A/D module, 0 to 8, where 0 is the RADBase and 1 to 8 corresponds to the A/D modules ac - The A coefficient in the polynomial bc - The B coefficient in the polynomial cc - The C coefficient in the polynomial nl - end of line |
| Example | A series of voltages have been applied using the A2DCAL command. To generate the third order polynomial for the A/D correction for module 1, Type: A2DTCALC 1 6 The RAD software will calculate the polynomial coefficients and return them. They will not be written to the ID chip until IDPWRITE and IDPCONFIRM commands have been executed. |
| Note | This command will only generate the correction coefficients. Coefficients are written to the A/D module ID chip using the IDPWRITE command. |

BANK A MODE

| | |
|----------------|--|
| Command | BANK A MODE |
| Command Syntax | BANKA <CR> |
| Arguments | None |
| Description | Commands the ERAD4000 to switch the DOUTs set in the configuration variable: BANKA. This command is intended for use with ZOC22, 23, and 33 modules but could be used in any situation where DOUT settings must be changed quickly. |
| Returns | <nl> - end of line |
| Example | To switch the valves in a ZOC 22, 23, or 33 to measure the pressures applied to the Bank A inputs: Enter the command: BANKA The ERAD4000 will switch the outputs based on the setting of the configuration variable: BANKA. This command assumes that the configuration variable is set correctly. |

BANK B MODE

| | |
|----------------|--|
| Command | BANK B MODE |
| Command Syntax | BANKB <CR> |
| Arguments | None |
| Description | Commands the ERAD4000 to switch the DOUTs set in the configuration variable: BANKB. This command is intended for use with ZOC22, 23, and 33 modules but could be used in any situation where DOUT settings must be changed quickly. |
| Returns | <nl> - end of line |
| Example | To switch the valves in a ZOC 22, 23, or 33 to measure the pressures applied to the Bank B inputs: Enter the command: BANKB The ERAD4000 will switch the outputs based on the setting of the configuration variable: BANKB. This command assumes that the configuration variable is set correctly. |

BANK USER MODE

| | |
|----------------|---|
| Command | BANK USER MODE |
| Command Syntax | BANKUSR<CR> |
| Arguments | None |
| Description | Commands the ERAD4000 to switch the DOUTs set in the configuration variable: BANKUSR. This command is intended for use with ZOC22, 23, and 33 modules but could be used in any situation where DOUT settings must be changed quickly. |
| Returns | <nl> - end of line |
| Example | To switch the valves in a ZOC 22, 23, or 33 to a special mode of operation as defined in the configuration variable BANKUSR: Enter the command: BANKUSR The ERAD4000 will switch the outputs based on the setting of the configuration variable: BANKUSR. This command assumes that the configuration variable is set correctly. |

BOOTLOADER VERSION

| | |
|----------------|--|
| Command | BOOTLOADER VERSION |
| Command Syntax | BLVER <CR> |
| Arguments | None |
| Description | Requests the version number of the ERAD4000 Boot loader. |
| Returns | Boot loader Version: <version string> <n> |
| Example | To determine the version of an ERAD4000 Boot loader software in use type: BLVER<CR> The ERAD4000 will return: Bootloader Version: 2.12 |
| Note | This command will not return a version string for Boot loader versions 2.01 or older. This command is not active in ERAD4000 software versions 2.01 and older. |

CALIBRATE INSERT

| | |
|----------------|--|
| Command | CALIBRATE INSERT |
| Command Syntax | CALINS <pressure> <channels> <CR> |
| Arguments | pressure - a real number that represents the calibration pressure for this point channels - combination of: module-port for one channel; or: module-port,module-port for multiple modules; or module-port...module-port for a range of modules. Module is the physical location of the module in the system Port is a single pressure sample point within a module. |
| Description | This command reads one averaged frame of pressure and temperature counts and stores the information in memory in the INSERT format shown in the CALIBRATE Command. |
| Returns | <n> - end of line |
| Example | If a user wanted to calibrate a module connected to A/D position 3 at 15 psi: Apply CTL1 and CTL2 Control pressures Connect a pressure standard to the CAL input. Enter the command: CALINS 15 3-1..3-32<CR> The ERAD4000 will measure the counts for each channel and write the new master plane information into memory. |
| Note | The ERAD4000 does not control the calibration. It will only read the information when commanded. |

CALIBRATE ZERO

| | |
|----------------|--|
| Command | CALIBRATE ZERO |
| Command Syntax | CALZ<CR> |
| Arguments | None |
| Description | Commands the ERAD4000 to perform a zero calibration. This operation produces A/D count values for each pressure channel that is subtracted from the raw pressure counts before conversion to the engineering units. The data is stored in a Zero Array and a Delta Array. These values may be read by executing a ZERO or DELTA command. This command places the ERAD4000 in the CALZ Mode until the command is completed or a STOP command is issued. CALZ requires approximately 15 seconds to complete. |
| Returns | <nl> - end of line |
| Example | To update the current ZERO file and correct for any zero drift of the transducers: Enter the command: CALZ The ERAD4000 will measure the zero counts for each channel and update the Zero and Delta Arrays. The ERAD4000 will write the information into the file, ZERO.CFG when a SAVE Command is executed. |
| Note | It is very important that a user execute a CALZ after the ERAD4000 and ZOC modules have been allowed to stabilize after power up. Also a CALZ should be executed if power is cycled, or if a RESTART command is executed. The ERAD4000 will not load previously saved ZERO file without use of the ZLOAD command. |

CHANNEL

| | |
|----------------|--|
| Command | CHANNEL |
| Command Syntax | CHAN<scan group> <CR> |
| Arguments | <scan group> - the number 1, the only active scan group number |
| Description | This command outputs the channel configuration for the scan group entered in the argument. |
| Returns | CHAN: <group><sequence><mod><port><lpress> <hpress><numchan><eu><nl> group - the scan group, 1 sequence - the scan port number mod - the module number port - the port number in the module lpress - the minimum pressure value hpress - the maximum pressure value numchan - the number of channels in the module eu - the eu conversion setting, 0 = raw counts, 1 = EU nl - end of line |
| Example | To verify the which channels have been assigned to SCAN GROUP 1 Type: CHAN1 <CR> The ERAD4000 will return: CHAN: 1 1 1 1 -6.100000 6.100000 32 1 CHAN: 1 2 1 2 -6.100000 6.100000 32 1 CHAN: 1 3 1 3 -6.100000 6.100000 32 1 ::: ::: ::: ::: CHAN: 1 31 1 31 -6.100000 6.100000 32 1 CHAN: 1 32 1 32 -6.100000 6.100000 32 1 > This shows that all 32 ports of a 32 channel module have been assigned in sequence to Scan Group 1. The module is connected to input one. The minimum full scale pressure value is -6.1 engineering units. The maximum pressure value is 6.1 engineering units. The output data will be in engineering units. |

CLEAR

| | |
|----------------|--|
| Command | CLEAR |
| Command Syntax | CLEAR<CR> |
| Arguments | None |
| Description | Commands the ERAD4000 to clear any errors that have occurred. The errors are sent to the client in response to an ERROR command. |
| Returns | <nl> - end of line |
| Example | To clear any errors listed in the ERROR Buffer, the following command would be issued: CLEAR<CR> The ERROR buffer will be cleared. |
| Note | Errors are not stored in Versions 1.00 through 1.03 |

CLEAR ACCUMULATED ERROR BUFFER

| | |
|----------------|--|
| Command | CLEAR ACCUMULATED ERROR BUFFER |
| Command Syntax | CLEARERROR<CR> |
| Arguments | None |
| Description | Commands the ERAD4000 to clear the Accumulated Error Buffer. This buffer is not the same as the standard error buffer. |
| Returns | <nl> - end of line |
| Example | To clear any errors listed in the ACCUMULATED ERROR Buffer, the following command would be issued: CLEARERROR<CR> The ACCUMULATED ERROR Buffer will be cleared |
| Note | This command is not active in the ERAD4000 software versions 2.01 or older. |

CONTROL PRESSURE RESET

| | |
|----------------|---|
| Command | CONTROL PRESSURE RESET |
| Command Syntax | DOUTPU<CR> |
| Arguments | None |
| Description | Resets the control pressures to the power up condition. This will reset control pressures if the BANKA, BANKB, and BANKUSR commands are used to modify control pressure settings from the power up condition. This also will reset DOUTS that have been manually set. Scanivalve Corp recommends that all ZOC22, ZOC23, and ZOC33 modules have all control pressures removed if the modules will be powered on for a long time. |
| Returns | <nl> - end of line |
| Example | To reset the control pressures to the power up mode after several operations of the BANK(x) commands, type: DOUTPU<CR> |

DELETE

| | |
|----------------|---|
| Command | DELETE |
| Command Syntax | DELETE <start temp> <end temp> [<channels>]<CR> |
| Arguments | <p>start temp - an integer from 0 to 69 that represents the low point of the temperature planes to delete</p> <p>end temp - an integer from 0 to 69 that represents the high point of the temperature planes to delete</p> <p>channels - optional, a channel to be deleted. This may be in the format: module-port or serial number-port for a single module. module-port..module-port or serial number-port..serial number-port for a range of channels</p> |
| Description | Converts all pressure points within temperature planes between the low and high temperature range, inclusive, to "calculated". This allows new MASTER points to be entered via the INSERT command. |
| Returns | <nl> - end of line |
| Example | <p>To delete the master points for all modules in a system using eight 32 channel modules, the following command would be issued: DELETE 0 69 1-1..8-32<CR></p> <p>To delete the master points for channels 49 through 56 in a ZOC33 connected to input six, the following command would be issued: DELETE 0 69 6-49..6-56<CR></p> <p>To delete the master points for channel 3 in a ZOC17 connected to input four, the following command would be issued: DELETE 0 69 4-3<CR></p> |

DELTA

| | |
|----------------|---|
| Command | DELTA |
| Command Syntax | DELTA <module> <CR> |
| Arguments | module - module position 1 through 8 |
| Description | Lists the active delta zero correction values that resulted from a CALIBRATE ZERO. These values are used in the conversion of raw counts to Engineering Units (EU). These variables can only be set by executing a CALIBRATE ZERO command. If a module number is not entered, the DELTA values for all active modules are listed. |
| Returns | DELTA: <channel> <value> <nl> DELTA: <channel> <value> <nl> ::: DELTA: <channel> <value> <nl> channel - the channel in module-port format value - the zero correction values nl - end of line. |
| Example | To view the DELTA values for the module connected to input one: Type: DELTA 1<CR> The RAD4000 will return the current delta values DELTA: 1-1 40 DELTA: 1-2 38 DELTA: 1-3 29 DELTA: 1-4 31 ::: DELTA: 1-10 34 DELTA: 1-11 35 DELTA: 1-12 27 ::: DELTA: 1-29 30 DELTA: 1-30 29 DELTA: 1-31 20 DELTA: 1-32 29 > |
| Notes | Delta values are the difference between the current CALZ zero value and the zero value stored in the calibration coefficients. The values tend to be low when a module has been recently calibrated and increase slowly over time as the sensors drift. It is very important that a user execute a CALZ after the ERAD4000 and ZOC modules have been allowed to stabilize after power up. Also a CALZ should be executed if power is cycled, or if a RESTART command is executed. The Zero and Delta Arrays are cleared when the ERAD4000 is powered down or when a RESTART command is executed. The data in the ZERO.cfg file is intended to be historical data. The Zero and Delta values are not reloaded at power up or restart because it is impossible to determine how long the power has been off. This also is designed to ensure that a new set of zeros is acquired if modules have been switched. |

DOUT

| | |
|----------------|--|
| Command | DOUT |
| Command Syntax | DOUT <discrete channel> <status> <CR> |
| Arguments | discrete channel - a digital output channel 1 through 64 status - 1=On 0=Off |
| Description | Commands the discrete output channel on or off |
| Returns | <nl> - end of line |
| Example | In this example, digital output channel 1(RDS number 1, channel 1 in address location 9) will be energized: DOUT 1 1 <CR> In this example, digital output channel 11 (RDS number 2 channel 3 in address location 10)will be de-energized. DOUT 11 0 <CR> |
| Note | The DOUT channels correspond to a channel in an RDS3200 module. If the corresponding RDS module is not installed, an error will be reported. |

ERROR

| | |
|----------------|--|
| Command | ERROR |
| Command Syntax | ERROR<CR> |
| Arguments | None |
| Description | Lists the errors that have occurred since the last CLEAR. Only the first 80 errors will be listed. If more than 80 errors have occurred, the message: "ERROR: Max errors exceeded" will appear at the end of the list. |
| Returns | ERROR: <error message><nl> ERROR: <error message><nl> ::: ERROR: <error message><nl> error message - an error message shown in the error list. nl - end of line. |
| Example | To read the contents of the Error Buffer: Type: ERROR The ERAD4000 will return the last 30 errors in the format:: ERROR: Module or Port not found ERROR: List MI no group number ERROR: Group not between 1 and 8 If no errors have been logged, the ERAD4000 will return: ERROR: No errors |
| Note | The Error Buffer is only updated if the configuration variable: IFUSER , is set to 0. When IFUSER is set to 1, errors will be displayed as they occur. This is not supported in Versions 1.00 through 1.03. |

FILE

| | |
|----------------|--|
| Command | FILE |
| Command Syntax | FILE <filename><CR> |
| Arguments | filename - The file to be opened. The file must be on the MicroSD card. |
| Description | Opens the named file. It is assumed that this file will be a series of SET or LIST commands. This command will not support commands that change the state of the ERAD i.e. SCAN, CALZ, SAVE, etc. The FILE command is not a Macro function, that is, it will execute each command in the file in order without waiting for each command to be completed. |
| Returns | <nl> - end of line |
| Example | A startup command list may be sent to the ERAD4000. A file: scan.cmd may contain the commands: SET FPS1 1 SCAN The file: scan.cmd is located in the ERAD folder. To execute the file, Type: FILE scan.cmd<CR> |
| Note | This command is not active in ERAD4000 software versions 2.01 or older. The file naming format must conform to the DOS standard format: xxxxxxxx.yyy |

FILL

| | |
|----------------|---|
| Command | FILL |
| Command Syntax | FILL<CR> |
| Arguments | None |
| Description | Sorts and Fills the Conversion Table temperature planes in ascending order. |
| Returns | <nl> - end of line |
| Example | In this example, new MASTER points have been loaded and the coefficient table must be completed. Type: FILL<CR> The FILL command only needs to be used if MASTER points are added to, or deleted from the coefficients and the program is not restarted. When the program is started, restarted, or reloaded, The MASTER points are loaded into memory from the Module Profile Files and a FILL is executed by the program. |

GET ACCUMULATED ERRORS

| | |
|----------------|--|
| Command | GET ACCUMULATED ERRORS |
| Command Syntax | GETERROR [file name on FTP server]<CR> |
| Arguments | None |
| Description | <p>Lists the accumulated errors that have occurred since the last CLEARERROR and the number of occurrences for each of these errors. Accumulated errors are a limited number of errors that might have an effect on the data. The Errors are:</p> <ul style="list-style-type: none"> Module M temperature below 0 degrees C Module M temperature above 69 degrees C A/D temperature above 69 degrees C A/D temperature below 0 degrees C FTP Server Connection Retries <p>File name on the FTP server is the file where the errors will be written. If file name on FTP server is left blank, the errors will be written to the host screen. The error count will accumulate until the accumulated buffer is cleared with the CLEARERROR command.</p> |
| Returns | <p>ERROR: <Error Message> occurrences <count><nl> ERROR: <Error Message> occurrences <count><nl> ERROR: <Error Message> occurrences <count><nl> ERROR: <Error Message> occurrences <count><nl> Error message - an error message shown in the description above. Count - The number of occurrences nl - end of line.</p> |
| Example | <p>EXAMPLE1 To read the contents of the Accumulated Error Buffer: Type: GETERROR The ERAD4000 will return any of the errors listed above that might have occurred. ERROR: Module 1 temperature below 0 degrees C occurrences 9 ERROR: A/D temperature below 0 degrees C occurrences 5 If no errors have been logged, the ERAD4000 will return: ></p> <p>EXAMPLE2 To write the contents of the Accumulated Error Buffer to a file on the FTP server: Type: GETERROR error.log The ERAD4000 will write the contents of the Accumulated Error buffer to the file: Error.log on the FTP Server.</p> |

INSERT

| | |
|----------------|---|
| Command | INSERT |
| Command Syntax | INSERT <temp> <channel> <press> <press counts> M<CR> |
| Arguments | temp - an integer from 0 to 69 that represents the temperature in °C channel - a combination of module and port. Syntax is module-port or serial number- port for one channel. press - a real number that represents the calibration pressure point press counts - a signed integer from 32767 to -32768 that represents the current pressure counts from the sensor. |
| Description | Inserts one pressure-pressure counts entry into the Correction Table. Only master points are accepted. The LIST MASTER and LIST ALL commands download the contents of the conversion table in the format required by this INSERT command. If a MASTER plane is overwritten, an error will be generated. |
| Returns | <nl> - end of line |
| Example | <p>Although INSERT commands are most often entered from a Module Profile File, they may be entered from a keyboard.</p> <p>The following command will insert a master point at 30.5°C for channel 1 of the module installed in position 3. The applied pressure is 11.9998 psi, the measured counts are 26376. INSERT 30.50 3-1 11.9998 26376 M</p> <p>The following command will insert a master point at 48.75°C for channel 59 of the module installed in position 3. The applied pressure is 10.9998 psi, the measured counts are 20254. INSERT 48.75 3-59 10.9998 20254 M</p> <p>The following command will insert a master point at 43.75°C for channel 26 of module serial number 209. The applied pressure is -2.4864 psi, the measured counts are -6651. INSERT 43.75 209-26 -2.4864 -6651 M</p> |

LIST A/D CORRECTION TABLE

| | |
|----------------|---|
| Command | LIST A/D CORRECTION TABLE |
| Command Syntax | LIST A2DTCOR <module> <temp><CR> |
| Arguments | module - The A/D location, 0 to 8. Where 0 is the temperature A/D and 1 to 8 are the module locations. t index - The temperature index, 0 to 7 |
| Description | Lists the correction coefficients for the A/D in the specified location |
| Returns | A2DTCOR <module> <t index> <temp><p index> <voltage> <counts><ideal counts> module - 0 to 8, Where 0 is the temperature A/D in the RADBASE and 1 to 8 are the module A/D's. t index - the calibration point, each module may have up to 8 points. Each of these points may have up to 16 correction points. temp - The actual temperature of the index point, read from the ID chip. p index - Index point, 0 through 16 where the applied voltage, measured counts and ideal counts are read. voltage - the voltage applied at the p index calibration point. counts - the A/D counts measured at the p index calibration point ideal counts - the ideal counts at the p index point at the applied voltage, based on the formula: $\text{Ideal Counts} = \frac{\text{Applied Volts} \times 2.852}{10} \times 32767$ |
| Example | To list the coefficients for the A/D converter in A/D module 1: Type: LIST A2DTCOR 1 1<CR> The RAD will return: A2DTCOR 1 25 0.000000 0 0.000000 0 0 A2DTCOR 1 25 0.000000 1 0.000000 0 0 A2DTCOR 1 25 0.000000 2 0.000000 0 0 A2DTCOR 1 25 0.000000 3 0.000000 0 0 A2DTCOR 1 25 0.000000 4 0.000000 0 0 A2DTCOR 1 25 0.000000 5 0.000000 0 0 A2DTCOR 1 25 0.000000 6 0.000000 0 0 A2DTCOR 1 25 0.000000 7 0.000000 0 0 A2DTCOR 1 25 0.000000 8 0.000000 0 0 A2DTCOR 1 25 0.000000 9 0.000000 0 0 A2DTCOR 1 25 0.000000 10 0.000000 0 0 A2DTCOR 1 25 0.000000 11 0.000000 0 0 A2DTCOR 1 25 0.000000 12 0.000000 0 0 A2DTCOR 1 25 0.000000 13 0.000000 0 0 A2DTCOR 1 25 0.000000 14 0.000000 0 0 A2DTCOR 1 25 0.000000 15 0.000000 0 0 |

LIST ALL CONVERSION COEFFICIENTS

| | |
|----------------|--|
| Command | LIST ALL CONVERSION COEFFICIENTS |
| Command Syntax | LIST A <start temp> <end temp> <channels><CR> |
| Arguments | start temp - the lowest temp plane to be returned end temp - the highest temp plane to be returned channels - a combination of module and a port. Syntax is: module-port or Serial number-port for one channel |
| Description | Lists all of the master points in the temperature-pressure correction matrix. This command places the ERAD4000 in the LIST mode until the command is completed or a STOP command is issued. |
| Returns | INSERT <temp><channel><press><press counts><M><nl> INSERT <temp><channel><press><press counts><M><nl> ::: INSERT <temp><channel><press><press counts><M><nl> temp - the temperature plane channel - the channel in module-port notation press - the pressure in EU press counts - the A/D counts of pressure M - a Master Plane generated from a calibration nl - end of line. |
| Example | To list all of the coefficients from 16°C to 20°C for channel 1 in a module calibrated from 17°C to 40°C Type: LIST A 16 20 1-1<CR> The ERAD4000 will return a list of INSERT commands showing the temperature, channel, applied pressure, and counts INSERT 17.00 1-1 -45.949100 -26184 M INSERT 17.00 1-1 -19.969601 -11302 M INSERT 17.00 1-1 0.000000 162 M INSERT 17.00 1-1 19.984600 11636 M INSERT 17.00 1-1 45.949100 26586 M |
| Note | The LIST A and LIST M commands are identical in the ERAD4000 firmware |

LIST BOOTLOADER GROUP VARIABLES

| | |
|----------------|--|
| Command | LIST BOOTLOADER GROUP VARIABLES |
| Command Syntax | LIST IP <CR> |
| Arguments | None |
| Description | Lists the Identification configuration variables from Group IP. |
| Returns | <pre>SET <variable> <value> <nl> SET <variable> <value> <nl> ::: SET <variable> <value> <nl></pre> <p>variable - the configuration variable name value - the current setting nl - end of line.</p> |
| Example | <p>To view the current Boot Loader Group Variables settings: Type: LIST IP<CR></p> <p>The ERAD4000 will return the current boot loader variable settings. They could appear as follows.</p> <pre>SET IPADD 191.30.140.104 SET SUBNET 255.255.0.0 SET MAC 000.096.093.400.000.103 SET LOGIN Scanivalve SET PASSWORD Scanner SET LOGIN1 Scanivalve1 SET PASSWORD1 Scanner1 SET ALLOWANON 1 SET APP Rad4000.hex SET GW 10.0.0.1</pre> |
| Note | <p>Modifications to the variables in this group may result in one or more of the following conditions:</p> <ol style="list-style-type: none"> 1. Unstable network operation. 2. Problems completing FTP file transfers. 3. ERAD operational problems <p>The variables in this group are not saved when a SAVE command is issued. They may only be saved by using the SAVEIP command.</p> |

LIST CALIBRATION VARIABLES

| | |
|----------------|--|
| Command | LIST CALIBRATION VARIABLES |
| Command Syntax | LIST C<CR> |
| Arguments | None |
| Description | Lists the Conversion configuration variables from Group C. |
| Returns | <pre>SET <variable> <value> <nl> ::: SET <variable> <value> <nl> variable - the configuration variable name value - the current setting <nl> - end of line.</pre> |
| Example | <p>To view the current conversion variable settings: Type: LIST C<CR> The ERAD4000 will return the current conversion settings. They could appear as follows.</p> <pre>SET ZC 1 SET UNITSCAN psi SET CVTUNIT 1.000000 SET BIN 0 SET EU 1 SET CALZDLY 5 SET MPBS 0 SET CALPER 500 SET CALAVG 32 SET MAXEU 9999.00 SET MINEU -9999.00 SET STARTCALZ 0 SET FILLONE 0 SET A2DCOR 1 ></pre> <p>For more information, refer to "Conversion Variables (Group C)" on page 72.</p> |

LIST DIGITAL VARIABLES

| | |
|----------------|--|
| Command | LIST DIGITAL VARIABLES |
| Command Syntax | LIST D<CR> |
| Arguments | None |
| Description | Lists the Digital Configuration variables from Group D. |
| Returns | <pre>SET <variable> <value> <nl> SET <variable> <value> <nl> ::: SET <variable> <value> <nl> variable - the configuration variable name value - the current setting <nl> - end of line.</pre> |
| Example | <p>To view the current digital variable settings: Type: LIST D<CR> The ERAD4000 will return the current digital settings. They could appear as follows.</p> <pre>SET DOUTPU 5 SET DOUTCALZ SET DOUTPGSEQ 0 SET DOUTPG 0 SET DOUTSCAN 20 SET DLYPGSEQ 1 SET DLYPG 10 SET DOUTREADY 40 SET BANKA 0 SET BANKB 0 SET BANKUSR 0</pre> |

LIST FILES

| | |
|----------------|---|
| Command | LIST FILES |
| Command Syntax | DIR FILE<CR> |
| Arguments | None |
| Description | Lists the data files stored in the ERAD4000 folder on the ERAD4000 system computer hard disk drive. |
| Returns | <pre><filename> <nl> ::: <filename> <nl> <nl> filename - The data file name <nl> - end of line.</pre> |
| Example | <p>To list all data files stored on the ERAD4000 system computer hard disk drive: Type: DIR FILE<CR> The ERAD4000 will return a file list</p> <pre>lp.cfg 221 Rad4000.hex 525008 M351.MPF 177912 Sn.gpf 105 CV.GPF 870 Zero.cfg 2022 Nas.cfg 172 SSN.CFG 3</pre> |

LIST GAIN VARIABLES

| | |
|----------------|---|
| Command | LIST GAIN VARIABLES |
| Command Syntax | LIST G <module><CR> |
| Arguments | None |
| Description | Lists the active temperature gain set for the module from the Temperature Gain Group, Group G. Module may be the position or the serial number. This data is used to convert temperature counts to °C. This is the “M” term in the temperature characterization equation. The value of this term will vary based on the module type. Refer to the section on Temperature Gain Values in the Configuration Variable Section of this manual for more information on the values for the “M” terms. |
| Returns | SET TEMPMn <value><nl> n - The module position or the serial number value - The temperature gain value for module n <nl> - end of line. |
| Example | To verify the temperature gain setting for the module serial number 253, Type: LIST g 253<CR> The RAD4000 will return: SET TEMPM253 0.0228 The gain settings may also be verified by module location. To verify the temperature gain setting of the module connected to input 6, Type: LIST g 6<CR> The ERAD4000 will return: SET TEMPM6 0.0228 The temperature gain settings may be verified for all modules connected to the ERAD4000. Type: LIST g<CR> The ERAD4000 may return: SET TEMPM1 0.037058 SET TEMPM2 0.037058 SET TEMPM3 0.037058 SET TEMPM4 0.037058 SET TEMPM5 0.037058 SET TEMPM6 0.037058 SET TEMPM7 0.037058 SET TEMPM8 0.037058 > |

LIST ID CHIP IDENTIFICATION

| | |
|----------------|---|
| Command | LIST ID CHIP IDENTIFICATION |
| Command Syntax | LIST ID [<loc> <site> <device>]<CR> |
| Arguments | <loc> the ID chip location, 0 to 16 <site> the location type, Where: A = A/D module M = ZOC module D = Digital Module (RDS) |
| Description | Lists the ID chip identification information. |
| Returns | <index> <loc> <site> <device> <ID> <error> index - Line number, used for reference only loc - the ID chip location, 0 to 16 site - the location type, Where: A = A/D module M = ZOC module D = Digital Module device E = EPROM T = Temp S = Switch ID the chip ID number - This number is unique for each ID chip. error any error that may have occurred |
| Example | <p>To view all of the ID information of a RAD4000 with 2 A/D modules, an RDS, and a ZOC module installed in position 1, Type: LIST ID<CR> The ERAD4000 may return:</p> <pre>0 1 A T 28644c340000008f None 1 0 A T 286e4c3400000040 None 2 0 A T 28cddb460000000c None 3 1 A E 14ca251e010000f3 None 4 0 A E 142e8e1e01000045 None 5 1 M E 147524ef00000048 None 6 2 A T 28b1de460000003b None 7 2 A E 14e9251e0100001c None 8 9 D E 14ee241e01000054 None</pre> <p>To view the ID information of the ZOC module in location 1, Type: LIST ID 1 M E The ERAD4000 may return:</p> <pre>5 1 M E 147524ef00000048 None</pre> <p>To view the ID information of the A/D module in location 2, Type: LIST ID 2 A E The ERAD4000 may return:</p> <pre>7 2 A E 14e9251e0100001c None</pre> <p>To View the ID information of a typical RAD4000, Type: LIST ID The ERAD may return:</p> <pre>0 1 A T 28644c340000008f None 1 0 A T 286e4c3400000040 None 2 0 A T 28cddb460000000c None 3 1 A E 14ca251e010000f3 None 4 0 A E 142e8e1e01000045 None 5 2 A T 28b1de460000003b None 6 2 A E 14e9251e0100001c None 7 9 D E 14ee241e01000054 None</pre> |

LIST ID CHIP SETTINGS

| | |
|----------------|---|
| Command | LIST ID CHIP SETTINGS |
| Command Syntax | LIST IDP [<loc> <site> <device> <mem>] <CR> |
| Arguments | <loc> - the ID chip location, 1 to 8 <site> - the location type, Where: A = A/D module , M = ZOC module <device> - the device type, always E for EPROM <mem> - the memory type, Where: E = EPROM, P = PROM |
| Description | Lists the ID chip settings. |
| Returns | SET IDP <loc> <site> <device> <mem> <name> <value> loc - the ID chip location, 1 to 8 site - the location type, Where: A = A/D module, M = ZOC module device - the device type, always E for EPROM mem - the memory type, Where: P = PROM, E = EPROM name - the parameter name value - the parameter value |
| Example | <p>To view all of the ID chip information of the chip in A/D module in position 1: Type: LIST IDP 1 A<CR> The ERAD may return: SET IDP 1 A E P DFC 1 SET IDP 1 A E P DMC 0 SET IDP 1 A E P SN 111 SET IDP 1 A E P REV A SET IDP 1 A E P MDATE 7/1/2002 SET IDP 1 A E E ADCA 0.000000 SET IDP 1 A E E ADCB 0.996481 SET IDP 1 A E E ADCC 2.070793 SET IDP 1 A E E ECC 0.001499 SET IDP 1 A E E GAIN 0 SET IDP 1 A E E ACDATE 7/1/2002 SET IDP 1 A E E ADCD 6.50000</p> <p>To view all of the ID chip information of the chip in the ZOC module in position 1: Type: LIST IDP 1 M<CR> The ERAD may return: SET IDP 1 M E P DFC 2 SET IDP 1 M E P DMC 4 SET IDP 1 M E P SN 301 SET IDP 1 M E P REV A SET IDP 1 M E P MDATE 1/27/2000 SET IDP 1 M E E RTYPE 0 SET IDP 1 M E E RVALUE 1 SET IDP 1 M E E RCORA 0.000000 SET IDP 1 M E E RCORB 0.000000 SET IDP 1 M E E RCDATE 1/27/2000 SET IDP 1 M E E PCDATE 8/16/2002 SET IDP 1 M E E NPR1 15.000000 SET IDP 1 M E E NPR2 15.000000 SET IDP 1 M E E VALVE 1 SET IDP 1 M E E XDUCER 0</p> |

LIST IDENTIFICATION VARIABLES

| | |
|----------------|---|
| Command | LIST IDENTIFICATION VARIABLES |
| Command Syntax | LIST I <CR> |
| Arguments | Lists the Identification configuration variables from Group I. |
| Description | Lists the identification configuration variables from Group I. |
| Returns | <pre>SET <variable> <value> <nl> SET <variable> <value> <nl> ::: SET <variable> <value> <nl></pre> <p>variable - the configuration variable name value - the current setting nl - end of line.</p> |
| Example | <p>To verify the general module configuration settings: Type: LIST i<CR> The ERAD4000 may return:</p> <pre>SET NL 0 SET DISPIN 0* SET HAVENET 1* SET HAVEARINC 0* SET CONOUT 2* SET NETOUT 2* SET FORMAT 0 SET NETIN 1* SET IFUSER 1* SET ECHO 0 SET CAL 0 9600* SET CALSCHED 0 rp 0* SET AUX 0 9600 1* SET AUXSCHED 0 rp 0* SET RESCAN 0 0* SET TWOAD 1*</pre> |
| Note | Variables marked with an asterisk are not used in ERAD4000 firmware. They have been left in the software as place holders. They cannot be modified, but setup software that attempts to modify these parameters will not be affected. |

LIST MASTER CONVERSION COEFFICIENTS

| | |
|----------------|---|
| Command | LIST MASTER CONVERSION COEFFICIENTS |
| Command Syntax | LIST M <start temp> <end temp> [<channels>] <CR> |
| Arguments | <start temp> - The lowest temp plane to be returned. <end temp> - The highest temp plane to be returned. [<channels>] - channels is a the combination of module and a port. Syntax is: module-port or Serial Number-port for one channel |
| Description | Lists all of the Master Points in the temperature-pressure correction matrix. This command places the ERAD4000 in the LIST mode until the command is completed or a STOP command is issued. |
| Returns | INSERT <temp><channel><press><press counts>M<nl> : : : INSERT <temp><channel><press><press counts> M<nl> temp - the temperature plane channel - the channel in module-port or serial number-port notation press - the pressure in EU press counts - the A/D counts of pressure M - indicates this is a Master Plane nl - end of line |
| Example | To view the Master Points between 10°C and 40°C for channel 1 of the module connected to input 1: Type: List m 10 40 1-1<CR> The ERAD4000 may return: INSERT 14.00 1-1 -5.958100 -21594 M INSERT 14.00 1-1 -4.476100 -15127 M INSERT 14.00 1-1 -2.994200 -8646 M INSERT 14.00 1-1 -1.470100 -1973 M INSERT 14.00 1-1 0.000000 4467 M INSERT 14.00 1-1 1.470100 10917 M INSERT 14.00 1-1 2.994200 17594 M INSERT 14.00 1-1 4.476100 24098 M INSERT 14.00 1-1 5.958100 30603 M INSERT 23.25 1-1 -5.958100 -21601 M INSERT 23.25 1-1 -4.476100 -15161 M INSERT 23.25 1-1 -2.994300 -8714 M INSERT 23.25 1-1 -1.470100 -2077 M INSERT 23.25 1-1 0.000000 4332 M INSERT 23.25 1-1 1.470100 10746 M INSERT 23.25 1-1 2.994200 17397 M INSERT 23.25 1-1 4.476100 23863 M INSERT 23.25 1-1 5.958100 30333 M INSERT 32.75 1-1 -5.958100 -21636 M INSERT 32.75 1-1 -4.476100 -15214 M INSERT 32.75 1-1 -2.994200 -8784 M INSERT 32.75 1-1 -1.470100 -2162 M INSERT 32.75 1-1 0.000000 4228 M INSERT 32.75 1-1 1.470100 10615 M INSERT 32.75 1-1 2.994200 17246 M |
| Note | List A and List M commands are identical in the ERAD4000 firmware |

LIST MODULE INFORMATION VARIABLES

| | |
|----------------|--|
| Command | LIST MODULE INFORMATION VARIABLES |
| Command Syntax | LIST MI <module><CR> |
| Arguments | <module> - module group 1 through 8 or module serial number |
| Description | Lists the configuration variables from Groups M1 through M8. If the module is not identified, all modules are listed. Each Module Information Group has provisions for up to four comment lines. These lines may be used to aid in the identification of the module group. |
| Returns | <pre> REM<module> 1 <comment> <nl> REM<module> 2 <comment> <nl> REM<module> 3 <comment> <nl> REM<module> 4 <comment> <nl> SET <variable> <value> <nl> SET <variable> <value> <nl> ::: SET <variable> <value> <nl> variable - the configuration variable name value - the current setting nl - end of line.</pre> |
| Example | <p>To view the configuration of the module connected to ERAD4000 A/D 1, Type: LIST mi 1<CR> The ERAD4000 may return:</p> <pre> REM1 1 Comment line 1 REM1 2 Comment line 2 REM1 3 Comment line 3 REM1 4 Comment line 4 SET TYPE1 0 SET ENABLE1 1 SET NUMPORTS1 32 SET NPR1 5 SET LPRESS1 1..32 -6.100000 SET HPRESS1 1..32 6.100000 SET NEGPTS1 1..32 4 SET MODTEMP1 0 1.000000 ></pre> |

LIST NETWORK ATTACHED STORAGE VARIABLES

| | |
|----------------|---|
| Command | LIST NETWORK ATTACHED STORAGE VARIABLES |
| Command Syntax | LIST NAS<CR> |
| Arguments | None |
| Description | Lists the Network Attached Storage Variables from Group NAS. |
| Returns | <pre> SET <variable> <value> <nl> SET <variable> <value> <nl> ::: SET <variable> <value> <nl> variable - the configuration variable name value - the current setting nl - end of line.</pre> |
| Example | <p>To view the current digital variable settings: Type: LIST NAS<CR> The ERAD4000 will return the current digital settings. They could appear as follows.</p> <pre> SET USERNAS scanconas SET PASSNAS scanco SET ENNAS 0 SET PATHNAS /rad4000 SET IPNAS 191.30.130.105 SET FILENAS Scan 0 SET ENNTP scanco SET ITPNTP 10.0.0.1 SET UTCCOFFSET -8 ></pre> |

LIST OFFSET VARIABLES

| | |
|----------------|--|
| Command | LIST OFFSET VARIABLES |
| Command Syntax | LIST O <module> <CR> |
| Arguments | None |
| Description | Lists the active temperature offsets set for the module from the Temperature Offset Group, Group O. These data are used to convert temperature counts to °C. This is the “B” term in the temperature characterization equation. The value of this term will vary based on the module type. Refer to the section on Temperature Gain Values in the Configuration Variable Section of this manual for more information on the values for the “B” terms. |
| Returns | SET TEMPBn <value> <nl> n - the module position or serial number value - the current setting nl - end of line. |
| Example | <p>To verify the temperature offset setting for the module serial number 253, Type: LIST O 253<CR> The ERAD4000 will return: SET TEMPB253 -259.7403</p> <p>The offset settings may also be verified by module location. To verify the temperature offset setting of the module connected to input 6, Type: LIST O 6<CR> The ERAD4000 will return: SET TEMPB6 -259.7403</p> <p>The temperature offset settings may be verified for all modules connected to the ERAD4000. Type: LIST O<CR> The RAD4000 may return: SET TEMPB1 -259.740234 SET TEMPB2 -259.7403 SET TEMPB3 -259.7403 SET TEMPB4 -259.7403 SET TEMPB5 -259.7403 SET TEMPB6 -259.7403 SET TEMPB7 -259.7403 SET TEMPB8 -259.7403 ></p> |

LIST PROFILE LIST SETTINGS

| | |
|----------------|--|
| Command | LIST PROFILE LIST SETTINGS |
| Command Syntax | LIST P<CR> |
| Arguments | None |
| Description | Lists the Installed module serial numbers from the Serial Number Profile Group, Group P. This data is used to create Module Profile Files that will hold module specific configuration variables. |
| Returns | <pre> SET RAD4000SN <value> <nl> SET SN1 <value> <nl> SET SN2 <value> <nl> ::: SET SN8 <value> <nl> value - the serial number of the module installed at that location nl - end of line.</pre> |
| Example | <p>To Verify the module input configuration Type: LIST P<CR> The ERAD4000 may return:</p> <pre> SET RADSN 104 SET SN1 253 SET SN2 0 SET SN3 0 SET SN4 0 SET SN5 0 SET SN6 0 SET SN7 0 SET SN8 0 ></pre> |
| Note | If a module is not detected at boot up, during a RESTART, or after a LIST SYS U command, the software will use the last known configuration. |

LIST REAL TIME DATA ANALYSIS SETTINGS

| | |
|----------------|--|
| Command | LIST REAL TIME DATA ANALYSIS SETTINGS |
| Command Syntax | LIST SA<CR> |
| Arguments | None |
| Description | Lists the Statistical Average Calculation configuration variables from Group SA. For more information on these calculations, refer to “Real Time Data Analysis Group Configuration Variables (Group SA)” on page 96. |
| Returns | SET <variable> <value> <nl> SET <variable> <value> <nl> ::: SET <variable> <value> <nl> variable - the configuration variable name value - the current setting nl - end of line. |
| Example | To verify the Statistical Average Calculation Configuration Variable settings of the ERAD. Type: LIST SA<CR> The ERAD will return: SET SA 1 SET SAACCUM 16 SET SAROLLAVG 1 SET SAMAX 1 SET SAMIN 1 SET SARMS 1 SET SASDEV 1 SET SAAVGXO 1 SET SAOL 1 In this example: 1. The Statistical Average calculations have been enabled. 2. The Cumulative Average is 16 samples, Each calculated value will be the rolling average of 16 samples. 3. All of the calculation outputs have been enabled. |

LIST SCAN VARIABLES

| | |
|----------------|---|
| Command | LIST SCAN VARIABLES |
| Command Syntax | LIST S<CR> |
| Arguments | None |
| Description | Lists the General Scan configuration variables from Group S. |
| Returns | <pre>SET <variable> <value> <nl> SET <variable> <value> <nl> ::: SET <variable> <value> <nl></pre> <p>variable - the configuration variable name value - the current setting nl - end of line.</p> |
| Example | <p>This command is used to verify the general scan settings of the ERAD4000</p> <p>Type: LIST S<CR></p> <p>The ERAD4000 will return:</p> <pre>SET PERIOD 500 SET ADTRIG 0 SET SCANTRIG 0 SET PAGE 0 SET QPKTS 0 SET BINADDR 0 0.0.0.0 SET IFC 62 0 SET TIMESTAMP 1 SET FM 1 SET TEMPPOLL 1 ></pre> |

LIST SCAN GROUP VARIABLES

| | |
|----------------|--|
| Command | LIST SCAN GROUP VARIABLES |
| Command Syntax | LIST SG <group><CR> |
| Arguments | <group> - The number 1 for the only active scan group |
| Description | Lists the Scan Group configuration variables from Group G1 |
| Returns | <p>SET <variable> <value> <nl> SET <variable> <value> <nl> ::: SET <variable> <value> <nl> variable - the configuration variable name value - the current setting nl - end of line.</p> <p>If no channels are assigned to a scan group, the following will be returned for a channel variable: SET CHAN< scan group >0<nl> For more information, refer to "Channel" on page 29</p> |
| Example | <p>When the SET CHANn parameter is modified, it must be set to 0 before the new channel configuration is entered. If not, the new configuration will be appended to the existing configuration. For example: if a 64 channel module is assigned to Scan Group 1, the SET CHAN variable will be:1-1..1-64, If the module is changed to a 32 channel module and the channel assignment is not set to 0 before the new assignment: 1-1..1-32 is added, the channel assignment will appear as follows: SET CHAN1 1-1..1-64 SET CHAN1 1-1..1-32</p> <p>This also applies in cases where a user has software to configure the scan groups prior to a test. If a scan group has channels defined and the channels are defined again without setting the channels to 0 first, the channel assignment will appear twice. If Scan Group 1 has a 32 channel module assigned and it is re-assigned by an initialization program, the channel assignments will appear as follows: SET CHAN1 1-1..1-32 SET CHAN1 1-1..1-32</p> |

LIST SYSTEM COMPONENTS

| | |
|----------------|--|
| Command | LIST SYSTEM COMPONENTS |
| Command Syntax | LIST SYS [<U>]<CR> |
| Arguments | blank - the existing system information, as determined at power up, will be displayed. No data will be updated. <U> - the system information will be updated and displayed. |
| Description | Lists the system information. This is the same information displayed at power up. This command must be run when system changes are made after power up. |
| Returns | RAD4000 Serial Number N LOC A2DSN -MODEL- -SN- CHAN VALVE -NPR1- -NPR2- XDUCER -CAL-DATE- 1 2 3 4 5 6 7 8 LOC -MODEL- -SN- CHAN DESCRIPTION 9 10 11 12 13 14 15 16 |

| Command | LIST SYSTEM COMPONENTS |
|---------|--|
| Example | <p>To view the current System Information as determined at power up: Type: LIST SYS<CR> The ERAD4000 will return: RAD4000 Serial Number 103 LOC A2DSN -MODEL- -SN- CHAN VALVE -NPR1- -NPR2- XDUCER -CAL-DATE- 1 111 ZOC33 300 64 X1 15.00 15.00 DIF 8/16/2009 2 110 : 8 LOC -MODEL- -SN- CHAN DESCRIPTION 9 RDS 103 8 REMOTE DIGITAL SWITCH [DOUT 1-8] 10 11 12 13 14 15 16</p> <p>The ERAD4000 is Serial number 103. It has two RAD A/D 3200 modules connected. RAD A/D3200 Sn 111 is installed in Location 1, ZOC33 Sn 300 is connected to this A/D module. The ZOC33 has 64 channels. It is not duplexed. The Full Scale pressure range of the module is 15.00 psi. The module is set up as a normal Differential Pressure Module. It was last calibrated August 16, 2009.</p> <p>RAD A/D3200 Sn 110 is installed in location 2. If a ZOC module is connected to this A/D, it does not have an ID Chip installed, or the ID Chip is not responding. RDS3200 Sn 103 is installed in location 9. The DOUT commands will function correctly</p> <p>If the first RDS module is not installed in position 9, the data return will appear as follows: RAD4000 Serial Number 103 LOC A2DSN -MODEL- -SN- CHAN VALVE -NPR1- -NPR2- XDUCER -CAL-DATE- 1 111 ZOC33 300 64 X1 15.00 15.00 DIF 8/16/2009 2 110 3 : 8 LOC -MODEL- -SN- CHAN DESCRIPTION 9 10 RDS 103 8 REMOTE DIGITAL SWITCH [DOUT 9-16] 11 12 13 14 15 16 WARNING: No RDS present at location 9</p> |
| Note | <p>Positions 1 through 8 are reserved for A/D modules. Positions 9 through 16 are reserved for RDS modules. All positions do not have to be filled. The positions are identified by the setting of the dip switches on the A/D and RDS modules. The first RDS module must always be identified as position 9. If the first RDS is installed in a position other than 9, the DOUT commands will not function. Also, an error will be returned at bootup and after a LIST SYS command.</p> |

LIST SYSLOG VARIABLES

| | |
|----------------|--|
| Command | LIST SYSLOG VARIABLES |
| Command Syntax | LIST SYSLOG <CR> |
| Arguments | None |
| Description | Lists the Syslog configuration variables. See Group SYSLOG for more information. |
| Returns | SET <variable> <value> <nl> SET <variable> <value> <nl> ::: SET <variable> <value> <nl> variable - the configuration variable name value - the current setting nl - end of line |
| Example | To view the current Syslog variable settings: Type: LIST SYSLOG<CR> The ERAD4000 will return the current Syslog variables. They could appear as follows: SET ENSYSLOG 1 SET LEVEL 3 SET IPSYSLOG 10.0.0.1 |

PURGE

| | |
|----------------|---|
| Command | PURGE |
| Command Syntax | PURGE<CR> |
| Arguments | None |
| Description | <p>Commands the ERAD4000 to initiate a purge sequence. This command may be initiated by entering the command from the local system computer or a host computer. The ERAD4000 must be in the READY mode. The purge sequence is:</p> <ol style="list-style-type: none"> 1. The digital output are set according to the DOUTPGSEQ variable. 2. The output remain set for a delay time set by the DLYPGSEQ variable. 3. When DLYPGSEQ times out, the digital output are set according to the DOUTPG variable. 4. The digital output will remain set until the DLYPG variable is met or until a STOP command is issued. 5. When DLYPG times out or when a STOP command is received the digital output are set according to the DOUTPGSEQ variable. 6. The output remain set for a delay time set by the DLYPGSEQ variable. 7. When DLYPGSEQ times out, the ERAD4000 returns to the READY mode. <p>When a purge is initiated by a digital input, the ERAD4000 may be in the READY mode or in the SCAN mode. The purge sequence is the same as above unless the ERAD4000 is in the SCAN mode. If the ERAD4000 is in the SCAN mode, the scanning will be suspended until the purge sequence is completed. At that time scanning will be resumed.</p> |
| Returns | nl - end of line |
| Example | To initiate a PURGE sequence: Type: PURGE<CR> |

READ

| | |
|----------------|---|
| Command | READ |
| Command Syntax | READ<CR> or ?<CR> |
| Arguments | None |
| Description | This command will only function when the Real Time Data Analysis (RTDA) function is enabled. When RTDA is enabled and a SCAN command is issued, the system will commence scanning and collect data for the RTDA function. No data is output until a READ command is issued. When a READ command is issued, the system will collect and output one "snapshot" frame of data. |
| Returns | One frame of Data will be output to the host computer or the NAS device depending on the setup of the NAS configuration variables. |
| Example | None |

READ DIGITAL OUTPUT

| | |
|----------------|---|
| Command | READ DIGITAL OUTPUT |
| Command Syntax | RDOUT<CR> |
| Arguments | None |
| Description | The RDOUT command allows the user to read the current settings of the digital outs. The RDOUT command only works from the READY mode. The status of the 8 digital outs is returned as a hex value. |
| Returns | 00000000 <nl> nl - end of line 00000000 is the value of each digital output starting with DOUT 8 as the left most bit and DOUT 1 as the right most bit. 0 indicates the DOUT is off, 1 indicates the DOUT is on. |
| Example | To query the state of the DOUTs, send the command: RDOUT The ERAD will return: 10100101 This indicates: Dout 8 - 1 Dout 7 - 0 Dout 6 - 1 Dout 5 - 0 Dout 4 - 0 Dout 3 - 1 Dout 2 - 0 Dout 1 - 1 |

REBOOT

| | |
|----------------|---|
| Command | REBOOT |
| Command Syntax | REBOOT<CR> |
| Arguments | None |
| Description | Commands the software to restart the Rad4000.hex program. |
| Returns | nl - End of line |
| Example | To initiate a Reboot sequence, Type: REBOOT<CR> |

RESET SEQUENCE NUMBER

| | |
|----------------|---|
| Command | RESET SEQUENCE NUMBER |
| Command Syntax | RSTSEQ [<sequence start>] <CR> |
| Arguments | blank - the sequence number will be reset to 0000 <sequence start> - the sequence number will be reset to the number entered |
| Description | Resets the sequence number used to complete the file name when Network Attached Storage is enabled. |
| Returns | nl - end of line |
| Example | To reset the Sequence Number to 0000, Enter: RSTSEQ <CR> To reset the Sequence Number to 0100, Enter RSTSEQ 100 <CR> |
| Note | This command is only active when NAS is enabled |

RESTART

| | |
|----------------|--|
| Command | RESTART |
| Command Syntax | RESTART<CR> |
| Arguments | None |
| Description | Commands the software to restart the RAD4000.exe program |
| Returns | nl - end of line |
| Example | To initiate a Restart sequence Type: RESTART<CR> |

SAVE

| | |
|----------------|--|
| Command | SAVE |
| Command Syntax | SAVE [<file name>] <CR> |
| Arguments | file name - Optional - All Configuration parameters will be saved to this file. |
| Description | Commands the ERAD4000 to save the configuration variables, and correction tables to disk., If the optional file is not specified, data is saved to a file named cv.gpf on the ERAD4000 hard disk drive. If the optional file is specified, data is saved to that file in the current ERAD4000 folder unless a different path is specified. |
| Returns | nl - end of line |
| Example | To save the current configuration variable settings and conversion coefficients without specifying a file, Type: SAVE<CR> To save the current configuration variable settings and conversion coefficients to a specific file, Type: SAVE config.txt<CR> |
| Note | A SAVE command may require several minutes to complete its execution depending on the number of .MPF files on the disk. It is recommended that the SAVE CV command be used to save configuration changes. |

SAVE BOOTLOADER VARIABLES

| | |
|----------------|---|
| Command | SAVE BOOTLOADER VARIABLES |
| Command Syntax | SAVEIP<CR> |
| Arguments | None |
| Description | <p>Commands the ERAD4000 to save the boot loader configuration variables to the Micro SD Card. Boot loader configuration variables are saved to the ip.cfg file. The SAVEIP write process requires two commands to complete.</p> <ol style="list-style-type: none"> 1. The SAVEIP command stages the IP configuration variables and prepares the software to write to the Micro SD Card. This command does not actually perform the write. 2. The write process does not occur until a SAVEIPCONFIRM command is issued. The SAVEIPCONFIRM command is considered to be part of the SAVEIP command. |
| Returns | None |
| Example | <p>To save the current boot loader configuration variable settings Type: SAVEIP<CR></p> <p>The software will return the following message: WARNING: This action could cause network communication problems. Type SAVEIPCONFIRM confirm SAVEIP or STOP to cancel the operation. Type SAVEIPCONFIRM to complete the SAVE.</p> |
| Note | <p>Changes to the boot loader configuration variables will not take effect until power is cycled, or a REBOOT command is issued.</p> <p>The SAVEIP command requires approximately 60 seconds to complete. Normally, commands entered during this time would be ignored, but it is possible on rare occasions to cause the ERAD firmware to freeze.</p> |

SAVE CONFIGURATION VARIABLES

| | |
|----------------|---|
| Command | SAVE CONFIGURATION VARIABLES |
| Command Syntax | SAVE CV<CR> |
| Arguments | None |
| Description | Commands the ERAD4000 to save only the configuration variables to disk. The variables will be written to the file: cv.gpf |
| Returns | nl - end of line |
| Example | <p>To save the current configuration variable settings, Type: SAVE CV<CR></p> |
| Note | A SAVE CV command may require 20 seconds or more to complete |

SAVE NETWORK ATTACHED STORAGE VARIABLES

| | |
|----------------|---|
| Command | SAVE NETWORK ATTACHED STORAGE VARIABLES |
| Command Syntax | SAVENAS<CR> |
| Arguments | None |
| Description | Commands the ERAD4000 to save the Network Attached storage (NAS) configuration variables to the Micro SD Card. NAS configuration variables are saved to the nas.cfg file. |
| Returns | None |
| Example | To save the current NAS configuration variable settings type: SAVENAS<CR> |
| Note | Changes to the NAS configuration variables are not saved during an execution SAVE or SAVEIP command. |

SCAN

| | |
|----------------|--|
| Command | SCAN |
| Command Syntax | SCAN<CR> |
| Arguments | None |
| Description | <p>Commands the ERAD4000 to scan the pressure sensors and output scan data. The SCAN function operation depends on the setting of ADTRIG and SCANTRIG. The SCAN function is only active in the Network mode.</p> <p>ADTRIG = 0 SCANTRIG = 0</p> <p>The SCAN function will be initiated immediately when the SCAN command is received. Data will be acquired at the rate determined by the settings of PERIOD, AVGN and the Number of Channels in the modules being scanned. Data will be output in Averaged Frames as the Frames are ready until FPS is satisfied or a STOP Command is received.</p> <p>ADTRIG = 0 SCANTRIG = 1</p> <p>In this case, a hardware trigger will initiate the SCAN function. The Software trigger will not initiate the SCAN function. Data will be acquired at the rate determined by the settings of PERIOD, AVGN and the Number of Channels in the modules being scanned. Scanning will continue until FPS is satisfied or a STOP command is received. Multiple trigger pulses received during a scan will be ignored.</p> <p>ADTRIG = 1 SCANTRIG = 0</p> <p>In this case, the SCAN command only enables the scan function. The ERAD4000 will enter the WTRIG mode and wait for a hardware or software trigger. When a trigger is received, the RAD4000 will acquire and output one averaged frame of data and re-enter the WTRIG mode. Data will be acquired at the rate determined by the settings of PERIOD, AVGN and the Number of Channels in the modules being scanned. Multiple trigger pulses received during a scan will be ignored. When a Frame has been output, the next trigger will repeat the process. This will continue until the Frames per Scan Variable has been satisfied or a STOP command is received.</p> |

| | |
|---------|---|
| Command | SCAN |
| Returns | <p>The format of the returned data is based on the setting of the BIN configuration variable and FORMAT. If BIN is set to 1 the Scan Packets are returned in Binary Format(Refer to “Binary Scan Packets” on page 111 for more information). If BIN is set to 0, the scan packets are returned in ASCII Format as follows:</p> <p>If FORMAT is set to 1:</p> <pre><group> <frame> <channel> <pressure> <nl> <group> <frame> <channel> <pressure> <nl> :: :: :: :: <group> <frame> <channel> <pressure> <nl></pre> <p>group - the scan group number from 1 to 8 frame - the current frame number channel - the channel in module-port format pressure - the pressure in either counts or real number format based on the setting of the EU configuration variable. nl - end of line.</p> <p>If FORMAT is set to 0:</p> <pre>Group=<group> Frame=<frame> <channel1><pressure> <channel2><pressure> <channel3><pressure> <channel4><pressure> <channel5><pressure> <channel6><pressure> <channel7><pressure> <channel8><pressure> <channel9><pressure> <channel10><pressure> <channel11><pressure> <channel12><pressure> <channel13><pressure>.....<channelxx><pressure></pre> |
| Example | None |
| Note | <ol style="list-style-type: none"> 1. Only channels that are listed with the LIST SGN command are returned. The field length is not fixed. Scan Groups are returned as they are ready. 2. All frames are separate parsable frames. 3. HyperTerminal or ScanTel will display up to 512 channels if FORMAT is set to 1 4. If ADTRIG is set to 1, SCANTRIG must be set to 0. If SCANTRIG is set to 1, ADTRIG must be set to 0. |

SET

| | |
|----------------|--|
| Command | SET |
| Command Syntax | SET <name> <value> <CR> |
| Arguments | <p>name - the Configuration Variable to be set or modified</p> <p>value - the value to be assigned to that Configuration Variable.</p> |
| Description | Commands the ERAD4000 to set one of the Configuration Variables. When Configuration Variables are listed with the LIST command, the variables are output in the format required by the SET command. This enables the user to upload the data from a file that has been created by a LIST download. |
| Returns | nl - end of line |
| Example | <p>This command will change configuration variable settings. To set zero correction on:</p> <pre>Type: SET ZC 1<CR></pre> <p>To change the pressure units to Pascals:</p> <pre>Type: SET UNITSCAN PA<CR></pre> <p>To change the scan channels in Scan Group 2 from module 2, channels 1 through 64, to module 1, channels 1 through 16:</p> <pre>Type: SET CHAN2 0<CR> SET CHAN2 1-1..1-16<CR></pre> |

SLOTS

| | |
|----------------|---|
| Command | SLOTS |
| Command Syntax | SLOTS <channel> <CR> |
| Arguments | channel - The channel in module-port format |
| Description | Queries the ERAD4000 to return the 10 boundary pressures for the 9 pressure slots defined for a given channel. |
| Returns | <pre> Press 9 <pressure> <nl> Press 8 <pressure> <nl> Press 7 <pressure> <nl> Press 6 <pressure> <nl> Press 5 <pressure> <nl> Press 4 <pressure> <nl> Press 3 <pressure> <nl> Press 2 <pressure> <nl> Press 1 <pressure> <nl> Press 0 <pressure> <nl> </pre> |
| Example | <p>To determine the boundary pressures for channel 1 of the 5 psi module s/n 253 Type: SLOTS 253-1<CR> The ERAD4000 will return:</p> <pre> Press 9 6.10000 Press 8 4.88000 Press 7 3.66000 Press 6 2.44000 Press 5 1.22000 Press 4 0.00000 Press 3 -1.52500 Press 2 -3.05000 Press 1 -4.57500 Press 0 -6.10000 </pre> <p>The pressures applied during a calibration must be selected so that there are not two or more applied pressures in any slot. The module in the example above has been set up with 4 negative points. By default, it will have 4 positive points as a calibration must always include a zero point.</p> <p>In this example, the slots for channel 1 of a 15 psi module in input 2 is configured for 2 negative points Type SLOTS 2-1<CR> The ERAD4000 will return:</p> <pre> Press 9 15.00000 Press 8 12.85714 Press 7 10.71429 Press 6 8.57143 Press 5 6.42857 Press 4 4.28572 Press 3 2.14286 Press 2 0.00000 Press 1 -7.50000 Press 0 -15.00000 </pre> |

STATUS

| | |
|----------------|--|
| Command | STATUS |
| Command Syntax | STATUS<CR> |
| Arguments | None |
| Description | Commands the ERAD4000 to return the current status. |
| Returns | <p>STATUS: <current status><nl> Current status: one of the following: READY - The ERAD4000 is ready to accept any command. SCAN - The ERAD4000 is in the SCAN mode. The only commands that will be accepted are STATUS or STOP. CALZ - The ERAD4000 is executing a CALIBRATE ZERO command. The only commands that will be accepted are STATUS or STOP. IDPWRITE - The ERAD4000 is writing to the ID chip. The only commands that will be accepted are IDPCONFIRM and STOP. No other commands will be accepted. INVALID - The command entered is not a valid command for the current mode of operation. FDISK - The ERAD4000 is re-formatting the Micro SD Card. SAVE - The ERAD4000 is saving the application configuration variables and .MPF files. SAVEIP - The ERAD4000 is saving the Boot Loader IP configuration variables. PURGE - The ERAD4000 is in the PURGE mode CAL - The ERAD4000 is acquiring data for calibration nl - end of line.</p> |
| Example | <p>The STATUS command may be entered at any time. This is one of the commands that will not generate an error if entered while the ERAD4000 is not READY. If the STATUS command is entered while the ERAD4000 is on, but inactive, the ERAD4000 will return: STATUS: READY If the STATUS command is entered while the ERAD4000 is executing a Calibrate Zero command, the ERAD4000 will return: STATUS: CALZ</p> |

STOP

| | |
|----------------|--|
| Command | STOP |
| Command Syntax | STOP<CR> |
| Arguments | None |
| Description | Commands the ERAD4000 to abort the current operation and return to the READY mode. |
| Returns | nl - end of line |
| Example | To abort any function of operation, type: STOP<CR> |

TEMPERATURE

| | |
|----------------|---|
| Command | TEMPERATURE |
| Command Syntax | TEMP <units><CR> |
| Arguments | units - May be one of the following: RAW - Returns the temperature in raw counts. EU - Returns the temperature in Engineering Units |
| Description | Lists the current temperatures of all 8 modules. If a module is not connected, the returned temperature will be 0. |
| Returns | TEMP: 1 <temp> <nl> TEMP: 2 <temp> <nl> ::: TEMP: 8 <temp> <nl> temp - The module temperature in raw counts or engineering units nl - End of line. |
| Example | To view the current temperatures of the modules connected to the ERAD4000 Type: TEMP EU<CR> The ERAD4000 will return: TEMP: 1 28.00 TEMP: 2 105.75 TEMP: 3 00.00 TEMP: 4 00.00 TEMP: 5 00.00 TEMP: 6 00.00 TEMP: 7 00.00 TEMP: 8 00.00 To view the A/D counts of the temperature inputs Type: TEMP RAW<CR> The ERAD4000 will return: TEMP: 1 12551 TEMP: 2 32767 TEMP: 3 0 TEMP: 4 0 TEMP: 5 0 TEMP: 6 0 TEMP: 7 0 TEMP: 8 0 |
| Note | A counts reading of 32767 indicates an open input. A counts reading of 0 with an engineering unit of 0 indicates that the module is not enabled. |

TEMPERATURE GRADIENT COMPENSATION

| | |
|----------------|--|
| Command | TEMPERATURE GRADIENT COMPENSATION |
| Command Syntax | TGRAD<CR> |
| Arguments | None |
| Description | This command reads the temperature of the A/D modules and stores this information in a table. This table is then used to estimate the A/D module temperatures during a scan based on the temperature of the ERAD4000. |
| Returns | <Location> <ERAD4000 Temp> <A/D Temp> <Delta Temp> <nl> Location - A/D Location, 1 through 8 ERAD4000 Temp - Measured Temperature of the ERAD4000 in degrees C A/D Temp - Measured Temperature of the ERAD4000 A/D Module in this location. Delta Temp - The calculated Temperature differential for the A/D Module in this location. nl - End of line. |
| Example | A ERAD4000 has two A/D modules connected. To calculate and store the temperature differential for these modules, Type: TGRAD<enter> The ERAD4000 software will calculate the differential temperatures and return: Loc 1 Base 33.187500 Temp 28.562500 Delta -4.625000 Loc 2 Base 33.187500 Temp 27.750000 Delta -5.437500 Loc 3 Base 33.187500 Temp 0.000000 Delta -33.187500 Loc 4 Base 33.187500 Temp 0.000000 Delta -33.187500 Loc 5 Base 33.187500 Temp 0.000000 Delta -33.187500 Loc 6 Base 33.187500 Temp 0.000000 Delta -33.187500 Loc 7 Base 33.187500 Temp 0.000000 Delta -33.187500 Loc 8 Base 33.187500 Temp 0.000000 Delta -33.187500 |
| Note | The ERAD4000 software can only read the temperature of the ERAD4000 when in the scan mode. The temperature of the A/D modules connected to the ERAD4000 can be estimated based on the gradient calculation derived from the table generated by this command. |

TIME AVAILABILITY TEST

| | |
|----------------|--|
| Command | TIME AVAILABILITY TEST |
| Command Syntax | TIME<CR> |
| Arguments | None |
| Description | This command tests the Network Time Protocol (NTP) Server specified in the IPNTP configuration variable. If a Time can be retrieved, it will be returned. If the Time Server cannot be found, an error is returned |
| Returns | The Time, if The Time Server can be found, or an Error, if the Time Server cannot be found Time in the format: YYYYMMDD_HHMMSS Where: YYYY is the year MM is the month (1 to 12) DD is the day (1 to 7) HH is the hour in 24 hour format MM is the minute SS is the seconds Error The message: ERROR: Time Server cannot be found nl - End of line. |
| Example | None |
| Note | The time will be derived from either the NAS device or a NTP server. This will be determined by the setting of GW in the IP Group. If a valid NTP IP address is set for GW, the time will be derived from the NTP server at that address. If the address set in GW is the default setting, or an invalid NTP server address, the date and time will be derived from an attached NAS device. If a NAS is not attached, an ERROR will be generated. |

VERSION

| | |
|----------------|---|
| Command | VERSION |
| Command Syntax | VER<CR> |
| Arguments | None |
| Description | Requests the version number of the Rad4000.hex file. |
| Returns | VERSION: <version string> <nl> |
| Example | To determine the version of Rad4000.hex software in use: Type: VER<CR> The ERAD4000 will return: VERSION: 2.04 |

WRITE ID CHIP VARIABLES

| | |
|----------------|--|
| Command | WRITE ID CHIP VARIABLES |
| Command Syntax | IDPWRITE <address> <site> <device> <mtype><CR> |
| Arguments | <p>address - The location of the device. Valid values are 0 through 8, Where 0 can only be the Temperature A/D.</p> <p>site - A for an A/D, or M for a Module</p> <p>device - The memory device in the A/D or module. This must always be E for EPROM. The software will select the Device family based on the Name to be modified.</p> <p>mtype - E for EPROM, or P for PROM. Data stored in PROM may only be set once. If PROM data are set at the Scanivalve Factory, they may not be modified in the field. Data stored in EPROM may be modified by a user.</p> |
| Description | The ID Chip write process requires two commands to complete. The IDPWRITE command stages the ID chip identification variables and prepares the software to write to the ID Chip PROM or EPROM. This command does not actually perform the write. The write process does not occur until a IDPCONFIRM command is issued. The IDPCONFIRM command is considered to be part of the IDPWRITE command |
| Returns | <p>SET IDP <address> <site> <device> <mtype> <name> <value></p> <p>address - The location of the device. Valid values are 0 through 8, Where 0 can only be the ERAD4000 Temperature A/D.</p> <p>site - A for an A/D, or M for a Module</p> <p>device - The memory device in the A/D or module. This must always be E for EPROM. The software will select the Device family based on the Name to be modified.</p> <p>mtype - E for EPROM, or P for PROM. Data stored in PROM may only be set once. If PROM data is set at the Scanivalve Factory, they may not be modified in the field. Data stored in EPROM may be modified by a user.</p> <p>name - The name of the variable</p> <p>value - The value of the variable</p> |
| Example | <p>The IDP variables for the EPROM in a ZOC module have been programmed using the SET IDP Variable commands. When all of the variables have been set, the ERAD software must be set up to write to the EPROM. The following command is entered:</p> <pre>IDPWRITE 1 M E E</pre> <p>The ERAD returns the following:</p> <pre>SET IDP 1 M E E RTYPE 0 SET IDP 1 M E E RVALUE 1 SET IDP 1 M E E RCORA 0.000000 SET IDP 1 M E E RCORB 0.000000 SET IDP 1 M E E RCDATE 1/26/2004 SET IDP 1 M E E PCDATE 1/1/2000 SET IDP 1 M E E NPR1 1.000000 SET IDP 1 M E E NPR2 1.000000 SET IDP 1 M E E VALVE 2 SET IDP 1 M E E XDUCER 0</pre> <p>Type IDPCONFIRM to confirm IDP write or STOP to escape</p> <p>If the data is correct, issue the IDPCONFIRM command to write the variables to the EEPROM. If the data is not correct, type STOP and repeat the process to correct the errors.</p> |

ZERO

| | |
|----------------|--|
| Command | ZERO |
| Command Syntax | ZERO <module><CR> |
| Arguments | module - the module position 1 through 8 or the serial number |
| Description | Lists the active zero correction values obtained from a CALIBRATE ZERO command. This data is used in the conversion of raw counts to Engineering Units (EU). These values may only be set by executing a CALIBRATE ZERO. If a module number is not entered, the ZERO values for all modules are listed. |
| Returns | ZERO: <channel> <value> <nl> ZERO: <channel> <value> <nl> ::: ZERO: <channel> <value> <nl> channel - the channel in module-port or serial number-port format value - the zero correction values nl - end of line. |
| Example | To view the current zeros for module 1 Type: ZERO 1<CR> The ERAD4000 will return: ZERO: 1-1 160 ZERO: 1-2 165 ZERO: 1-3 68 ZERO: 1-4 131 ZERO: 1-5 41 ZERO: 1-6 162 ZERO: 1-7 145 ZERO: 1-8 233 ZERO: 1-9 158 ::: ::: ZERO: 1-28 96 ZERO: 1-29 19 ZERO: 1-30 134 ZERO: 1-31 132 ZERO: 1-32 238 |
| Note | If a module number is not entered, the zero values for all enabled modules will be returned. |

ZERO LOAD

| | |
|----------------|--|
| Command | ZLOAD |
| Command Syntax | ZLOAD<CR> |
| Arguments | None |
| Description | Commands ERAD to load the saved Zero.cfg file from memory. |
| Returns | None |
| Example | None |

CONFIGURATION VARIABLES**GENERAL SCAN VARIABLES (GROUP S)****ADTRIG**

| | |
|---------------|---|
| Variable | ADTRIG<code> |
| Valid Values | 0 or 1 |
| Default Value | 0 |
| Data Type | Integer |
| Description | <p>This variable determines the method for a Frame Trigger.</p> <p>0 - Frame timing is controlled by an internal timer set by PERIOD.</p> <p>1 - Frame timing is controlled by an external hardware or a software trigger. When ADTRIG is enabled, a frame will be triggered whenever a hardware or software trigger input is received. The hardware trigger is a hard wired input to the power input connector. The Software trigger is a TAB, or Ctrl I, character. When a SCAN command is received, the ERAD4000 enters a WAIT state until a trigger pulse is received. At that time, the ERAD4000 will acquire and output one averaged frame of data then re-enter the WAIT state. This will continue until a STOP command is received or the FPS variable is satisfied. Multiple trigger pulses received during a scan will be ignored.</p> <p>NOTE If ADTRIG is set to 1, SCANTRIG must be set to 0. Use of ADTRIG will not report accurate timestamps.</p> |

BINADDR

| | |
|---------------|---|
| Variable | BINADDR <port> <IP address> |
| Valid Values | port - 0 to 65535 IP address - any valid IP address |
| Default Value | port - 0 IP address - 0.0.0.0 |
| Data Type | Integer |
| Description | When port is set to 0, data is NOT sent out over the binary address port, data is sent over the standard TCP port. When port is set to 0, this does not imply that TCP data is sent over port 0. If port is 1 to 65535, data is sent over that port to the IP address identified in a UDP format. |

IFC

| | |
|---------------|---|
| Variable | IFC <char 1> <char 2> |
| Valid Values | char 1 - any valid ASCII character char 2 - any valid ASCII character |
| Default Value | char 1 - 62 char 2 - 0 |
| Data Type | Integer |
| Description | This variable sets the interframe characters to be used when transmitting ASCII unformatted output. If only one character is desired, char 2 must be set to 0. If both characters are set to 0, no interframe characters will be transmitted. |

PERIOD

| | |
|---------------|---|
| Variable | PERIOD <period> |
| Valid Values | 20 to 65535 |
| Default Value | 500 |
| Data Type | Integer |
| Description | <p>This master period variable sets the sample rate, in microseconds, of the pressure A/D converters and the one temperature A/D converter. Period is the dwell time between channels. Period is only one of the terms required to determine data rate. Data rate is determined by the equation:</p> $\text{Data Rate} = \frac{1}{\text{Period} \times \text{Channels} \times \text{Average}}$ <p>Data rate is expressed in Hertz per channel Period is in microseconds Channels is the number of channels in the largest module enabled Average is the average term for that scan group</p> |

SCANTRIG

| | |
|---------------|---|
| Variable | SCANTRIG <code> |
| Valid Values | 0 or 1 |
| Default Value | 0 |
| Data Type | Integer |
| Description | <p>Controls scan initiation.</p> <p>0 - Scanning is initiated by the SCAN command.</p> <p>1 - Scanning is initiated by an external hardware trigger. When SCANTRIG is enabled, a scan will be initiated whenever a hardware trigger input is received. The hardware trigger is a hard wired input to the power cable. The scan function will continue until the Frames per Scan variable is satisfied or a STOP command is received. Multiple trigger pulses received during a scan will be ignored.</p> <p>If SCANTRIG is set to 1, ADTRIG must be set to 0. A Software Trigger will not initiate the SCAN function.</p> |

FM

| | |
|---------------|--|
| Variable | FM <code> |
| Valid Values | 1 |
| Default Value | 1 |
| Data Type | Integer |
| Description | This variable is not used in the ERAD4000 firmware. It is a place holder only. |

PAGE

| | |
|---------------|--|
| Variable | Page <code> |
| Valid Values | 1 |
| Default Value | 1 |
| Data Type | Integer |
| Description | This variable is not used in the ERAD4000 firmware. It is a place holder only. |

QPKTS

| | |
|---------------|--|
| Variable | QPKTS <code> |
| Valid Values | 1 |
| Default Value | 1 |
| Data Type | Integer |
| Description | This variable is not used in the ERAD4000 firmware. It is a place holder only. |

TEMPOLL

| | |
|---------------|--|
| Variable | TEMPOLL <code> |
| Valid Values | 1 |
| Default Value | 1 |
| Data Type | Integer |
| Description | This variable is not used in the ERAD4000 firmware. It is a place holder only. |

TIMESTAMP

| | |
|---------------|--|
| Variable | TIMESTAMP <code> |
| Valid Values | 0 or 1 |
| Default Value | 1 |
| Data Type | Integer |
| Description | This variable sets the time stamp units. The Time Stamp is the elapsed time from the start of the scan function. The first time stamp will always be zero. TIMESTAMP data are only output to a file when BIN is set to 1. TIMESTAMP data are never output when the data format is ASCII. 0 - Time is in microseconds 1 - Time is in milliseconds Timestamp does not report correct time with ADTRIG set to 1. |

CONVERSION VARIABLES (GROUP C)**BIN**

| | |
|---------------|---|
| Variable | BIN <code> |
| Valid Values | 0, 1, or 4 |
| Default Value | 0 |
| Data Type | Integer |
| Description | <p>Sets the format of the output data: (Refer to the packet definitions for more information)</p> <ul style="list-style-type: none"> 0 - Output is in ASCII 1 - Output is in binary format 2 - Output is in binary format (with module and port information) 3.- Not implemented in version 2.01 and higher 4 - Output is in binary format with a scan header <p>NOTE: The ERAD4000 does not support multiple scan groups. When BIN is set to 4, the value of FPS, AVG and Number of channels for scan groups 2 through 8 will be 0.</p> |

CALAVG

| | |
|---------------|--|
| Variable | CALAVG <sample average> |
| Valid Values | 2 to 256 |
| Default Value | 64 |
| Data Type | Integer |
| Description | Sets the calibration sample average. This value should be set to ensure that a sufficient number of samples will be acquired to ensure a stable, noise free calibration. |

CALPER

| | |
|---------------|--|
| Variable | CALPER <period> |
| Valid Values | 50 to 5000 |
| Default Value | 5000 |
| Data Type | Integer |
| Description | Sets the period, in microseconds, of the ERAD4000 calibration data acquisition. This is the same as PERIOD in the SCAN Group This value should be set to insure that a sufficient settling time exists so that the channel samples are stable. |
| NOTE | For versions 1.00 through 1.03 This variable is fixed at 500 microseconds For all versions 1.04 and higher CALPER will be set automatically to the value set in PERIOD, if PERIOD is 500 microseconds or less. If PERIOD is set to a value greater than 500 microseconds, the value of CALPER will be fixed at 500 microseconds. Users will not be able to modify this variable. |

CALZDLY

| | |
|---------------|--|
| Variable | CALZDLY <delay> |
| Valid Values | 1 to 128 |
| Default Value | 15 |
| Data Type | Integer |
| Description | Sets the delay time, in seconds, before the ERAD4000 executes a CALZ Command. This value should be set to ensure that a sufficient delay exists so that the Zero Offset data are not biased by residual pressure in the module calibration valves. |

CVTUNIT

| | |
|---------------|--|
| Variable | CVTUNIT <value> |
| Valid Values | Any real number |
| Default Value | 1.0 |
| Data Type | Float |
| Description | This is the conversion factor to convert from PSI units to the desired scanning units. This value may be set directly or by setting the UNITSCAN variable. |

EU

| | |
|---------------|--|
| Variable | EU <code> |
| Valid Values | 0, 1 |
| Default Value | 1 |
| Data Type | Integer |
| Description | Sets the units of output data: 0 - Output is in raw counts 1 - Output is in selected engineering units When the A/D counts reach 32767 or -32768, and EU is set to 1, the ERAD4000 will output the values set in MAXEU and MINEU to indicate that a conversion error may exist. The ERAD4000 will also output these values when the maximum or minimum master conversion planes are exceeded. |

FILLONE

| | |
|---------------|---|
| Variable | FILLONE <code> |
| Valid Values | 0, 1 |
| Default Value | 0 |
| Data Type | Integer |
| Description | This variable is NOT used in the ERAD4000 firmware. It is a placeholder only. |

MAXEU

| | |
|---------------|---|
| Variable | MAXEU <value> |
| Valid Values | Any valid floating point number |
| Default Value | 9999 |
| Data Type | Floating point |
| Description | <p>Sets the maximum Engineering Unit Value. This is the number that will be displayed when an overflow condition occurs.</p> <p>When the A/D counts reach 32767, and EU is set to 1, the ERAD4000 will output 9999 or whatever has been entered as the MAXEU value to indicate that a conversion error may exist. The ERAD4000 will also output these values when the maximum or minimum master conversion planes are exceeded.</p> |

MINEU

| | |
|---------------|---|
| Variable | MINEU <value> |
| Valid Values | Any valid floating point number |
| Default Value | -9999 |
| Data Type | Floating point |
| Description | <p>Sets the minimum Engineering Unit Value. This is the number that will be displayed when an overflow condition occurs.</p> <p>When the A/D counts reach -32768, and EU is set to 1, the ERAD4000 will output -9999 or whatever has been entered as the MINEU value to indicate that a conversion error may exist. The ERAD4000 will also output these values when the maximum or minimum master conversion planes are exceeded.</p> |

MPBS

| | |
|---------------|---|
| Variable | MPBS <number of planes> |
| Valid Values | 0 to 140 |
| Default Value | 5 |
| Data Type | Integer |
| Description | <p>When an INSERT command is issued and a master point is overwritten, a configurable number of temperature planes on either side of the new MASTER plane are converted to calculated. These points will be recalculated when a FILL command is executed. The number of planes to be entered in this variable may be calculated by the formula:</p> $\text{Planes} = \text{TEMP} \times 4$ <p>Where: TEMP is the number of degrees to be changed. For example, if it is desired to have points $\pm 4^\circ$ of the new master plane modified, then MPBS would be set to 16.</p> |

STARTCALZ

| | |
|---------------|--|
| Variable | STARTCALZ <code> |
| Valid Values | 0, 1 |
| Default Value | 0 |
| Data Type | Integer |
| Description | When set to 1, causes the ERAD4000 to execute a CALZ at startup. The ERAD4000 does not save zeros at power down. If the ERAD4000 is set to start scanning immediately or if it is difficult to input commands to the ERAD4000 once it is power up, then this variable should be set to 1. The ERAD4000 will then execute a CALZ at the end of the initialization sequence. |

UNITSCAN

| | |
|---------------|---|
| Variable | UNITSCAN <units> |
| Valid Values | See List Below |
| Default Value | PSI |
| Data Type | String |
| Description | This sets the output engineering units for the ERAD4000. Setting this value will also set CVTUNITS. CVTUNITS may be set to a different value, however UNITSCAN must be set first. The following are the list of units supported: ATM FTH2O KGM2 MH2O OZFT2 BAR GCM2 KIPIN2 MMHG OZIN2 CMHG INHG KNM2 MPA PA CMH2O INH2O KPA NCM2 PSF DECIBAR KGCM2 MBAR NM2 |
| Note | If a unit other than those listed is entered, the ERAD4000 will default to PSI. |

ZC

| | |
|---------------|---|
| Variable | ZC <code> |
| Valid Values | 0, 1 |
| Default Value | 1 |
| Data Type | Integer |
| Description | Enables or disables zero correction of the pressure data 0 - No zero correction is performed 1 - Zero correction is performed |

DIGITAL OUTPUT CONFIGURATION VARIABLES (GROUP D)**DLYPG**

| | |
|---------------|--|
| Variable | DLYPG <value> |
| Valid Values | 0 to 3600 |
| Default Value | 10 |
| Data Type | Integer |
| Description | Sets the time, in seconds, that the module inputs will be purged. This is only a part of the total purge sequence time. This timer can be interrupted by a STOP command. When set to 0, the time is infinite and the PURGE sequence can only be terminated by a STOP command. When a STOP command interrupts the PURGE sequence, only the DLYPG timer will be interrupted. The software will exit the PURGE sequence by stepping through the DLYPGSEQ settings and timing to prevent possible overpressure of the sensors. |

DLYPGSEQ

| | |
|---------------|--|
| Variable | DLYPGSEQ <value> |
| Valid Values | 0 to 60 |
| Default Value | 1 |
| Data Type | Integer |
| Description | Sets the time delay, in seconds, before purge air is applied to the modules. If 0 is entered, no delay will occur. |

DOUTCALZ

| | |
|---------------|---|
| Variable | DOUTCALZ <value> |
| Valid Values | 0 to FF Hexadecimal |
| Default Value | 0 |
| Data Type | Integer |
| Description | Enables digital outputs for a CALZ operation. Output 1 is the least significant binary bit. Output 8 is the most significant binary bit. The variable is entered as 2 hexadecimal digits. |

DOUTPG

| | |
|---------------|---|
| Variable | DOUTPG <value> |
| Valid Values | 0 to FF Hexadecimal |
| Default Value | 0 |
| Data Type | Integer |
| Description | Enables digital outputs for a PURGE sequence. Output 1 is the least significant binary bit. Output 8 is the most significant binary bit. The variable is entered in hexadecimal digits. |

DOUTPGSEQ

| | |
|---------------|---|
| Variable | DOUTPGSEQ <value> |
| Valid Values | 0 to FF Hexadecimal |
| Default Value | 0 |
| Data Type | Integer |
| Description | Enables digital outputs to transition from normal operation to PURGE operation. Output 1 is the least significant binary bit. Output 8 is the most significant binary bit. The variable is entered in hexadecimal digits. |

DOUTPU

| | |
|---------------|--|
| Variable | DOUTPU <value> |
| Valid Values | 0 to FF Hexadecimal |
| Default Value | 0 |
| Data Type | Integer |
| Description | Enables the digital outputs for normal power up configuration. Output 1 is the least significant binary bit. Output 8 is the most significant binary bit. The variable is entered in hexadecimal digits. |

DOUTSCAN

| | |
|---------------|---|
| Variable | DOUTSCAN <value> |
| Valid Values | 0 to FF Hexadecimal |
| Default Value | 40 |
| Data Type | Integer |
| Description | Enables the digital outputs to indicate that the ERAD4000 is in the SCAN mode. This variable ONLY effects the DOUT bit that is enabled. All other outputs are masked. Output 1 is the least significant binary bit. Output 8 is the most significant binary bit. The variable is entered in hexadecimal digits. |

DOUTREADY

| | |
|---------------|--|
| Variable | DOUTREADY <value> |
| Valid Values | 0 to FF Hexadecimal |
| Default Value | 80 |
| Data Type | Integer |
| Description | Enables the digital outputs to indicate that the ERAD4000 is in the READY mode. This variable ONLY effects the DOUT bit that is enabled. All other outputs are masked. Output 1 is the least significant binary bit. Output 8 is the most significant binary bit. The variable is entered in hexadecimal digits. |

BANKA

| | |
|---------------|---|
| Variable | BANKA <value> |
| Valid Values | 0 to FF Hexadecimal |
| Default Value | 0 |
| Data Type | Integer |
| Description | Enables the digital outputs to switch the control pressures in a ZOC22, 23 or 33 to measure the pressures in the Bank A inputs. Output 1 is the least significant binary bit. Output 8 is the most significant binary bit. The variable is entered in hexadecimal digits. |

BANKB

| | |
|---------------|--|
| Variable | BANKB <value> |
| Valid Values | 0 to FF Hexadecimal |
| Default Value | 0 |
| Data Type | Integer |
| Description | Enables the digital outputs to switch the control pressures in a ZOC22, 23 or 33 to measure the pressures in the Bank B inputs in a duplex module. Output 1 is the least significant binary bit. Output 8 is the most significant binary bit. The variable is entered in hexadecimal digits. |

BANKUSR

| | |
|---------------|---|
| Variable | BANKUSR <value> |
| Valid Values | 0 to FF Hexadecimal |
| Default Value | 0 |
| Data Type | Integer |
| Description | Enables the digital outputs to switch the control pressures in a ZOC22, 23, or 33 to a user defined mode. Output 1 is the least significant binary bit. Output 8 is the most significant binary bit. The variable is entered in hexadecimal digits. |

SCAN GROUP CONFIGURATION VARIABLES (GROUP G1 THROUGH G8)**AVG1**

| | |
|---------------|---|
| Variable | AVG1 <sample average> |
| Valid Values | 1 - 256 |
| Default Value | 16 |
| Data Type | Integer |
| Description | Sets the minimum number of samples to average for Scan Group 1. Refer to the CHANn variable for information on averaging of modules with a dissimilar number of channels. |

CHAN1

| | |
|---------------|---|
| Variable | CHAN1 <channels> |
| Valid Values | <channels> - channels is a combination of a module and a port. Syntax is: module-port for one channel module-port,module-port for many channels module-port..module-port for a range of channels Module is the physical location of the module in the rack or the connector supporting the module. Port is a single pressure sample point within a module. When 0 is entered, no channels are assigned to a scan group. |
| Default Value | 0 |
| Data Type | String |
| Description | Sets the channel assignments in scan group 1. Duplicate module-port entries are not permitted in the same module group. For example the notation: CHAN 1-1,1-1 is not valid. If a scan group contains ports from dissimilar modules, for example: a 64 port module and a 16 port module, the smaller module will be sampled more often in order to keep the larger module synchronized with the smaller module. The additional samples from the smaller module are averaged. In the previous example the 16 port module will be sampled 4 times for every one sample of the 64 port module. The order of the channels in the output frame is determined by the order of entry. Use the LIST SG1 command to verify the output frame order. Setting the channel variable does not automatically erase old channels. The user is responsible to insure that unwanted channels are cleared before new channels are set. The command : SET CHAN1 0<enter> will clear the scan group. |

FPSn

| | |
|---------------|--|
| Variable | FPSn <frames> Where n is the scan group number. |
| Valid Values | 0 - 2147483648 |
| Default Value | 0 |
| Data Type | Long Integer |
| Description | <p>Frames per Scan. Sets the number of averaged frames for Scan Group n to be output after a SCAN command is issued. Data will be output at a rate set by the formula below. Averaged frames will be output until the setting of FPS is met. Each Scan group may have a different value of FPS. When set to 0, the scan will continue until a stop command is received.</p> $\text{Data Rate} = \frac{1}{\text{Period} \times \text{Channels} \times \text{Average}}$ <p>Data Rate is expressed in Hertz per channel Period is in microseconds Channels is the number of channels in the largest module enabled AVG is the average term for that scan group</p> |

SGENABLE

| | |
|---------------|---|
| Variable | SGENABLE1 <code> |
| Valid Values | 0 or 1 |
| Default Value | 1 |
| Data Type | Integer |
| Description | <p>Enables the Scan Group output: 0 - Disabled 1 - Normal Scan Mode Enabled</p> |

SGENABLEn

| | |
|---------------|--|
| Variable | SGENABLEn <code> Where n is 2 through 8 |
| Valid Values | 0 or 1 |
| Default Value | 0 |
| Data Type | Integer |
| Description | This variable is not used in the ERAD4000 firmware. It is a place holder only. |

MODULE CONFIGURATION VARIABLES (M1 THROUGH M8)**ENABLEN**

| | |
|---------------|---|
| Variable | ENABLEn <enable> where n is the module position number |
| Valid Values | 0,1 |
| Default Value | 0 |
| Data Type | Integer |
| Description | Not used in ERAD4000 |

HPRESSN

| | |
|---------------|--|
| Variable | HPRESSn <ports> <pressure> where n is the module position number |
| Valid Values | <port> <pressure> port - one port port,port - many ports port..port - a range of ports pressure - a real number representing the pressure. |
| Default Value | 1..64 15.0 |
| Data Type | String |
| Description | Defines the maximum pressure for ports of the module n. |

LPRESSN

| | |
|---------------|--|
| Variable | LPRESSn <ports> <pressure> |
| Valid Values | <port> <pressure> port - one port port,port - many ports port..port - a range of ports pressure - a real number representing the pressure. |
| Default Value | 1..64 -15.0 |
| Data Type | String |
| Description | Defines the minimum pressure for ports of the module n. |

MODTEMPN

| | |
|---------------|---|
| Variable | MODTEMPn <port number> <scale factor> where n is the module position number |
| Valid Values | <port number> - the port position to display the module temperature <scale factor> - the temperature scaling factor |
| Default Value | 0 1.0 |
| Data Type | String |
| Description | Defines the module port number to display the module temperature and the temperature scaling factor. If EU is set to 1, the temperature output will be °C times the scale factor. If EU is set to 0, the temperature will be the displayed value divided by 4 |

NEGPTS_n

| | |
|---------------|--|
| Variable | NEGPTS _n <ports> <negpts> where n is the module position number |
| Valid Values | <port> - may be defined as: port - one port port,port - many ports port..port - a range of ports <negpts> - an integer that defines the number of master negative points. The maximum number of master negative points is 8. |
| Default Value | 1..64 4 |
| Data Type | String |
| Description | Defines the number of master negative points for port or ports of the module n. |

NPR_n

| | |
|---------------|--|
| Variable | NPR _n <pressure> where n is the module position number |
| Valid Values | Any valid integer up to 4 digits |
| Default Value | 15 |
| Data Type | Integer |
| Description | Defines the nominal pressure range for the module installed in position n. |

NUMPORTS_n

| | |
|---------------|--|
| Variable | NUMPORTS _n <ports> where n is the module position number |
| Valid Values | 16, 32, or 64 |
| Default Value | 64 |
| Data Type | Integer |
| Description | Defines the number of ports for the module n. |

TYPEN

| | |
|---------------|---|
| Variable | TYPEN <code> where n is the module position number |
| Valid Values | 0, 1, 2, 3 or 4 |
| Default Value | 0 |
| Data Type | Integer |
| Description | This variable defines the module n type: 0 - Standard 1 - Absolute 2 - Gauge 3 - True Differential 4 - Electrical Input Module |

MODULE PROFILE VARIABLES (GROUP P)***RAD4000SN***

| | |
|---------------|---|
| Variable | RAD4000SN <serial number> |
| Valid Values | Any valid integer up to 4 digits |
| Default Value | 0000 |
| Data Type | Integer |
| Description | The serial number of the RAD4000. This is a read only variable. |

SNN

| | |
|---------------|--|
| Variable | SNn <serial number> where n is the module position number |
| Valid Values | Any valid integer up to 4 digits |
| Default Value | 0000 |
| Data Type | Integer |
| Description | The serial number of the module installed in slot n. This is a read only variable. |

IDENTIFICATION CONFIGURATION VARIABLES (GROUP I)**AUX**

| | |
|---------------|---|
| Variable | AUX <code> |
| Valid Values | 1 |
| Default Value | 1 |
| Data Type | Integer |
| Description | This variable is not used in the ERAD4000 firmware. It is a placeholder only. |

AUXSCHED

| | |
|---------------|---|
| Variable | AUXSCHED <code> |
| Valid Values | 1 |
| Default Value | 1 |
| Data Type | Integer |
| Description | This variable is not used in the ERAD4000 firmware. It is a placeholder only. |

CAL

| | |
|---------------|---|
| Variable | CAL <code> |
| Valid Values | 0 |
| Default Value | 0 |
| Data Type | Integer |
| Description | This variable is not used in the ERAD4000 firmware. It is a placeholder only. |

CALSCHED

| | |
|---------------|---|
| Variable | CALSCHED <code> |
| Valid Values | 1 |
| Default Value | 1 |
| Data Type | Integer |
| Description | This variable is not used in the ERAD4000 firmware. It is a placeholder only. |

CONOUT

| | |
|---------------|---|
| Variable | CONOUT <code> |
| Valid Values | 2 |
| Default Value | 2 |
| Data Type | Integer |
| Description | This variable is not used in the ERAD4000 firmware. It is a placeholder only. |

DISPIN

| | |
|---------------|---|
| Variable | DISPIN <code> |
| Valid Values | 1 |
| Default Value | 1 |
| Data Type | Integer |
| Description | This variable is not used in the ERAD4000 firmware. It is a placeholder only. |

ECHO

| | |
|---------------|---|
| Variable | ECHO <enable> |
| Valid Values | 0 or 1 |
| Default Value | 0 |
| Data Type | Integer |
| Description | Determines if characters received from the network or the serial host will be echoed back to the host. 0 - Disabled 1 - Enabled |

FORMAT

| | |
|---------------|---|
| Variable | FORMAT <code> |
| Valid Values | 0 or 1 |
| Default Value | 0 |
| Data Type | Integer |
| Description | Determines if data is to be scrolled on the display 0 - Data is scrolled 1 - Data is displayed in place, formatted for a VT100 terminal |

HAVEARINC

| | |
|---------------|---|
| Variable | HAVEARINC <code> |
| Valid Values | 0 |
| Default Value | 0 |
| Data Type | Integer |
| Description | This variable is not used in the ERAD4000 firmware. It is a placeholder only. |

HAVENET

| | |
|---------------|---|
| Variable | HAVENET <code> |
| Valid Values | 1 |
| Default Value | 1 |
| Data Type | Integer |
| Description | This variable is not used in the ERAD4000 firmware. It is a placeholder only. |

IFUSER

| | |
|---------------|--|
| Variable | IFUSER <code> |
| Valid Values | 0 or 1 |
| Default Value | 1 |
| Data Type | Integer |
| Description | Determines the method of logging errors. 0 - All errors will be logged. Errors may only be accessed by issuing an ERROR command and cleared by issuing a clear command. 1 - All errors will be displayed as they occur |

NETIN

| | |
|---------------|---|
| Variable | NETIN <code> |
| Valid Values | 1 |
| Default Value | 1 |
| Data Type | Integer |
| Description | This variable is not used in the ERAD4000 firmware. It is a placeholder only. |

NETOUT

| | |
|---------------|---|
| Variable | NETOUT <code> |
| Valid Values | 2 |
| Default Value | 2 |
| Data Type | Integer |
| Description | This variable is not used in the ERAD4000 firmware. It is a placeholder only. |

NL

| | |
|---------------|---|
| Variable | NL <code> |
| Valid Values | 0 or 1 |
| Default Value | 0 |
| Data Type | Integer |
| Description | Determines the new line characters for all output 0 - <CR><LF> 1 - <CR> |

RESCAN

| | |
|---------------|---|
| Variable | RESCAN <code> |
| Valid Values | 1 |
| Default Value | 1 |
| Data Type | Integer |
| Description | This variable is not used in the ERAD4000 firmware. It is a placeholder only. |

TWOAD

| | |
|---------------|---|
| Variable | TWOAD <code> |
| Valid Values | 0 |
| Default Value | 0 |
| Data Type | Integer |
| Description | This variable is not used in the ERAD4000 firmware. It is a placeholder only. |

ID CHIP CONFIGURATION VARIABLES (GROUP ID)

IDP

| | |
|---------------|--|
| Variable | IDP <loc> <site> <device> <mem> <name> <value> |
| Valid Values | See Below |
| Default Value | Varies |
| Data Type | Integer |
| Description | <p>Sets the values in an ID Chip. This variable will be used rarely by a user. The ID chips are pre-programmed at the time of manufacture. It is recommended that a customer understand the information in the Section defining the ERAD ID Chip Data Format before attempting to modify a setting using this configuration variable.</p> <p>Loc - The location of the device. Valid values are 0 through 8, Where 0 can only be the Temperature A/D.</p> <p>Site - A for an A/D, M for a Module, or D for a Digital Module.</p> <p>Device - The memory device in the A/D or module. This must always be E for EPROM. The software will select the Device family based on the Name to be modified.</p> <p>Mem - The memory device type. P for PROM or E for EPROM. The Identification data stored in PROM cannot be modified by a user.</p> <p>Name - The name of the EEPROM data to be modified. Refer to the following lists of parameter names that may be modified.</p> <p>Value - The new value.</p> <p>Memory Device Type P (PROM) - All Family Codes - Values may not be modified by a user</p> <p>DFC Device Family Code 0 = ERAD Temperature A/D Board 1 = ERAD Pressure A/D Board 2 = Pressure Scanner Module 3 = ERAD Digital I/O Device 4 = Test Fixture (BASM3200) 5 = Voltage Scanner Module (EIM)</p> <p>DMC Device Model Code Family Code = 0 0 = 16 Bit 100 KHz, 5V Ref.</p> <p> Family Code = 1 0 = 16 Bit 100 KHz</p> <p> Family Code = 2 0 = ZOC 3016 1 = ZOC 17 2 = ZOC 22 3 = ZOC 23 4 = ZOC 33</p> <p> Family Code = 3 0 = Remote Digital Switch, 8 channels</p> <p> Family Code = 4 0 = BASM3200</p> <p> Family Code = 5 0 = ZOC16EIM 1 = ZOCEIM16 2 = ZOCEIM32</p> <p>SN - Serial Number Number 0 – 4096 REV - Revision Letter Code A – P MDATE - Manufacture Date MM/DD/YYYY</p> |

| Variable | IDP <loc> <site> <device> <mem> <name> <value> |
|------------------|--|
| Description Cntd | <p>Memory Device Type E (EEPROM) - Family Code 0</p> <p>ADCA A/D Correction Coefficient A The A coefficient of $Ax^2 + Bx + C$.</p> <p>ADCB A/D Correction Coefficient B The B coefficient of $Ax^2 + Bx + C$.</p> <p>ADCC A/D Correction Coefficient C The C coefficient of $Ax^2 + Bx + C$.</p> <p>ADCD A/D Correction Coefficient D The D coefficient used in the Temperature correction algorithm.</p> <p>RV - Reference Voltage - The measured voltage reference value used in the temperature calibration.</p> <p>ACDATE - A/D Calibration Date MM/DD/YYYY</p> <p>SN - ERAD Serial Number 0 – 4096</p> <p>APPTYPE ERAD Application Type 0 = Standalone 1 = ERAD</p> <p>Memory Device Type E (EEPROM) - Family Code 1</p> <p>ADCA - A/D Correction Coefficient A The A coefficient of $Ax^2 + Bx + C$.</p> <p>ADCB - A/D Correction Coefficient B The B coefficient of $Ax^2 + Bx + C$.</p> <p>ADCC - A/D Correction Coefficient C The C coefficient of $Ax^2 + Bx + C$.</p> <p>ECC - Excitation Current Correction Actual measured excitation current (1.5 mA ideal with exact 5V reference).</p> <p>GAIN - Gain Code 0 = 2.852 Gain (Standard)</p> <p>ACDATE - A/D Calibration Date MM/DD/YYYY</p> <p>Memory Device Type E (EEPROM) - Family Code 2</p> <p>RTYPE - RTD Type Code 0 = Platinum 385 1 = Nickel-Iron</p> <p>RVALUE RTD Value Code RTD Type Code = 0 0 = 100 Ohm 1 = 500 Ohm 2 = 1000 Ohm</p> <p>RTD Type Code = 1 0 = 604 Ohm</p> <p>RCORA - RTD Correction A A term for Callendar-Van Dusen equation.</p> <p>RCORB - RTD Correction B B term for Callendar-Van Dusen equation.</p> <p>RCDATE - RTD Calibration Date MM/DD/YYYY</p> <p>PCDATE - Pressure Sensor Cal Date MM/DD/YYYY</p> <p>NPR1 - Nominal Pressure Range 1 Value must be in PSI</p> <p>NPR2 - Nominal Pressure Range 2 Value must be in PSI</p> <p>VALVE - Pressure Valve Arrangement : 0 – No Valve 1 – X1 2 – X2 3 – NPx (Normal Px Mode) 4 – NO (Normal Open) 5 – IP</p> <p>XDUCER Transducer Type: 0 – Differential 1 – Delta 2 – Absolute</p> <p>Memory Device Type E (EEPROM) - Family Codes 3, 4, and 5 No programmable Values</p> |

TEMPERATURE OFFSET VARIABLES (GROUP O)**TEMPBN**

| | |
|---------------|--|
| Variable | TEMPBn <value> where n is the module position number |
| Valid Values | Any real number |
| Default Value | -259.7403 |
| Data Type | Float |
| Description | The "B" term in the conversion equation used to convert temperature counts to °C. If a module number is not specified, all modules will be displayed. This value is for a Platinum RTD (500Ω at 0°). The Conversion formula is: °C = (TempM x Counts) - TempB |

TEMPERATURE GAIN VARIABLES (GROUP G)**TEMPMN**

| | |
|---------------|--|
| Variable | TEMPMn <value> where n is the module position number |
| Valid Values | Any real number |
| Default Value | 0.037058 |
| Data Type | Float |
| Description | The "M" term in the conversion equation used to convert temperature counts to °C. If a module number is not specified, all modules will be displayed. This value is for a Platinum RTD (500Ω at 0°). The conversion formula is: °C = (TempM x Counts) - TempB |

Some ZOC modules use different RTD's for temperature measurement. The values of TEMPB and TEMPM may have been modified by the user when a different RTD is used. The following table lists the other RTD's that could be installed and the values of TMPB and TEMPM for each

| RTD | TEMPB | TEMPM | MODULES |
|------------------------------|-------------|----------|--|
| Nickel - Iron 604Ω at 0°C | -198.514371 | 0.023559 | ZOC16TC (Standard) ZOC22B (Standard) ZOC23B (Standard) DSA3016 (Standard) DSA3216 (Standard) |
| Platinum 100Ω at 0°C | -259.740234 | 0.185290 | ZOC22B (Special) ZOC23B (Special) ZOC33 (Special) |
| Platinum 500Ω at 0°C | -259.740234 | 0.037058 | ZOC33 (Standard) |
| Platinum 1000Ω at 0°C | -259.740234 | 0.018529 | ZOC22B (Special) ZOC23B (Special) ZOC33 (Special) |

BOOTLOADER IP CONFIGURATION VARIABLES

This group contains all of the network setup variables. All of these variables may be modified using the boot loader program, the serial connection, or the Ethernet connection. Changes to the variables in this group do not take effect until the AC power has been cycled.

Modifications to the variables in this group may result in one or more of the following conditions:

1. Unstable network operation
2. Problems completing FTP file transfers
3. ERAD operational problems

The Variables in this group are not saved when a SAVE command is issued. They may only be saved using the SAVEIP command followed by a SAVEIPCONFIRM.

IPADDR

| | |
|---------------|--|
| Variable | IPADDR <IP address> |
| Valid Values | Any valid IP address |
| Default Value | 191.30.40.xxx Where xxx is the serial number of the ERAD4000 |
| Data Type | Integer |
| Description | The IP address of the module. |

SUBNET

| | |
|---------------|--|
| Variable | SUBNET <Subnet mask> |
| Valid Values | Any valid subnet mask |
| Default Value | 255.255.0.0 |
| Data Type | Integer |
| Description | The subnet mask for the module. The subnet mask must be configured for the network where the ERAD will be connected. |

MAC

| | |
|---------------|---|
| Variable | MAC <MAC Address> |
| Valid Values | MAC 000.096.093.xxx.yyy.zzz |
| Default Value | 000.096.093.040.000.xxx Where xxx is the serial number of the ERAD4000 |
| Data Type | Integer |
| Description | The MAC address of the module. The last three octets may be modified by a user, but it is recommended that they not be modified. The first three octets MUST NOT be modified. These octets represent a setting registered to Scanivalve Corp. |

LOGIN

| | |
|---------------|---------------------------------|
| Variable | LOGIN <user name> |
| Valid Values | Any valid character string |
| Default Value | Scanivalve |
| Data Type | String |
| Description | The user name for the FTP login |

PASSWORD

| | |
|---------------|---|
| Variable | PASSWORD <password> |
| Valid Values | Any valid character string |
| Default Value | Scanner |
| Data Type | String |
| Description | The password associated with the user name for the FTP login. |

LOGIN1

| | |
|---------------|---|
| Variable | LOGIN1 <user name> |
| Valid Values | Any valid character string |
| Default Value | Scanivalve1 |
| Data Type | String |
| Description | The user name associated with the second FTP login. |

PASSWORD1

| | |
|---------------|--|
| Variable | PASSWORD1 <password> |
| Valid Values | Any valid character string |
| Default Value | Scanner1 |
| Data Type | String |
| Description | The password associated with the user name for the second FTP login. |

ALLOWANON

| | |
|---------------|--|
| Variable | ALLOWANON <code> |
| Valid Values | 0 or 1 |
| Default Value | 1 |
| Data Type | Integer |
| Description | Determines the new line characters for all output 0 - Do not allow anonymous FTP logins 1 - Allow anonymous FTP logins |

APP

| | |
|---------------|---|
| Variable | APP <application> |
| Valid Values | Any valid application name |
| Default Value | Rad4000.hex |
| Data Type | String |
| Description | The file name of the application to run. This is the file name that is used when automatically running the application from the boot loader. It is also the file name used when using the RUN command. If this file is not found, an error is returned. |

GW

| | |
|---------------|--|
| Variable | GW <IP addresss> |
| Valid Values | Any valid IP address |
| Default Value | 0.0.0.0 |
| Data Type | Integer |
| Description | This IP address will be used to access the NTP Server if the IPNTP address setting is an IP address outside the ERAD Subnet. |

NETWORK ATTACHED STORAGE CONFIGURATION VARIABLES (GROUP NAS)

This group contains the network attached storage configuration variables. All of these variables may be modified using the boot loader program, the serial connection, or the Ethernet connection.

Modifications to the variables in this group may result in one or more of the following conditions:

1. Unstable network storage operation
2. ERAD4000 operational problems

The variables in this group are not saved when a SAVE , or SAVEIP command is issued. They may only be saved by using the SAVENAS command.

ENNAS

| | |
|---------------|--|
| Variable | ENNAS <code> |
| Valid Values | 0, 1, or 2 |
| Default Value | 0 |
| Data Type | Integer |
| Description | Enables data to the NAS. 0 - Data is not sent to the NAS 1 - Data is sent to the NAS. A sequence number will be used to construct the file name. 2 - Data is sent to the NAS. The time, gathered from Network Time Protocol (NTP), will be used to construct the file name. |
| Example | If ENNAS is set to 1 and ENNTP is set to 0 or 1, a scan command will create a file on the NAS following format: <filename from FILENAS>_xxx .dat where: xxx is a sequence number from 000 to 999. The sequence number may be reset, or set using the Reset Sequence Number command. If ENNAS is set to 2, and ENNTP is set to 0 or 1, a scan command will create a file on the NAS with the following format: <filename from FILENAS>_yyyymmdd_hhmmss.dat where: yyyymmdd_hhmmss is date and time the file was created. The format is <year><month><day>_<hours><minutes><seconds>. |
| Note | The time will be derived from either the NAS device or a NTP server. This will be determined by the setting of GW in the IP Group. If a valid NTP IP address is set for GW, and ENNAS is set to 2, and ENNTP is set to 1, a file created on the NAS will get the time and date for the file from the NTP server at this address. If this address is set to the default setting, or an invalid NTP server address, the date and time will be derived from the NAS device. |

ENNTP

| | |
|---------------|---|
| Variable | ENNTP <Code> |
| Valid Values | 0 or 1 |
| Default Value | 0 |
| Data Type | Integer |
| Description | Enables the Network Time Protocol (NTP). 0 - Network Time Protocol is disabled 1 - Network time protocol is enabled |

FILENAS

| | |
|---------------|--|
| Variable | FILENAS <filename> [fix sequence switch] |
| Valid Values | Filename - any valid character string Fix sequence switch - 0 or 1 |
| Default Value | Scan 0 |
| Data Type | String |
| Description | File name Sets the data file prefix name. The file name will be completed with either a sequence number, or the date and time as documented in the description of ENNAS. Fix sequence switch, when set to 1, will lock the sequence number at 0000. If set to 0, the sequence number will increment with each scan. |

IPNAS

| | |
|---------------|---------------------------|
| Variable | IPNAS <IP Address> |
| Valid Values | Any valid IP Address |
| Default Value | 0.0.0.0 |
| Data Type | Integer |
| Description | The IP Address of the NAS |

IPNTP

| | |
|---------------|----------------------------------|
| Variable | IPNTP <IP Address> |
| Valid Values | Any valid IP address |
| Default Value | 0.0.0.0 |
| Data Type | Integer |
| Description | The IP Address of the NTP Server |

PASSNAS

| | |
|---------------|--|
| Variable | PASSNAS <password> |
| Valid Values | Any valid character string |
| Default Value | ScannerNas |
| Data Type | String |
| Description | The password associated with the user name for the login to the NAS. |

PATHNAS

| | |
|---------------|---|
| Variable | PATHNAS </Disk/Share> |
| Valid Values | Any valid path to the NAS disk |
| Default Value | /disk1/share |
| Data Type | String |
| Description | Sets the path on the NAS for the data file. This value must not include the drive designation, only the path on that drive. The FTP Server in the NAS should have the data destination defined as the root directory. |

USERNAS

| | |
|---------------|------------------------------------|
| Variable | USERNAS <User name> |
| Valid Values | Any valid character string |
| Default Value | ScanivalveNas |
| Data Type | String |
| Description | The user name for login to the NAS |

UTCOFFSET

| | |
|---------------|---|
| Variable | UTCOFFSET <offset> |
| Valid Values | Any valid number |
| Default Value | 0 |
| Data Type | Signed Integer |
| Description | The time offset from Coordinated Universal Time (UTC) |

REAL TIME DATA ANALYSIS GROUP CONFIGURATION VARIABLES (GROUP SA)

The Real Time Data Analysis Function is a special feature of the RAD Software. This feature will:

1. Output the data from the channels defined in Scan Group One as the Last Measured Value.
2. Perform a rolling average, as determined by the setting of SAACCUM, of the scan data for each channel enabled in Scan Group One only.
3. Calculate the, Maximum Value, Minimum Value, RMS Value, and Standard Deviation for each of these channels.
4. Eliminate any "outliers" of data outside the calculated standard deviation (3 sigma) from the rolling average.
5. Output a rolling average for each channel with the "outliers" excluded.
6. Output the number of overloads measured and excluded from the rolling average

The following configuration variables MUST be set for this feature to function correctly:

SET EU 1

SET ADTRIG 0

SET AVG1 1

SET FPS1 0

If BIN is set to 0, Data will be output to the TELNET port or the NAS in ASCII.

If BIN is set to 1, Data will be output to the NAS in binary.

SA

| | |
|---------------|---|
| Variable | SA <code> |
| Valid Values | 0 or 1 |
| Default Value | 0 |
| Data Type | Integer |
| Description | When set to 1, Enables the Real Time Data Analysis (RTDA) Calculations. If SA is set to 1, EU must be set to 1. RTDA calculations will only be performed on the channels enables in Scan Group One. |

SAACCUM

| | |
|---------------|--|
| Variable | SAACCUM <average> |
| Valid Values | 2 to 128 |
| Default Value | 16 |
| Data Type | Integer |
| Description | Sets the number of averaged data frames to be accumulated for the statistical calculations. The ERAD software will add the most current value to the accumulator and drop the oldest value at each new frame of data. |
| Note | The setting of this variable will affect the maximum data rate while RTDA is enabled. The maximum speeds obtained in tests at Scanivalve with 512 channels and all RTDA variables enabled are shown below. Results may vary depending on the installation. |

| SAACCUM | DATA (Hz/Ch) |
|---------|--------------|
| 2 | 45 |
| 4 | 38 |
| 8 | 33 |
| 16 | 26 |
| 32 | 17 |
| 64 | 11 |
| 128 | 7 |

SAROLLAVG

| | |
|---------------|--|
| Variable | SAROLLAVG <code> |
| Valid Values | 0 or 1 |
| Default Value | 0 |
| Data Type | Integer |
| Description | When set to 1, Enables the output of the rolling average value of each channel enabled in Scan Group One. This data is an average of the data in the accumulator for each channel. The output value is an average of the last number of frames set by the term SAACCUM. This data is output as Scan Group 2 in the output data file. |

SAMAX

| | |
|---------------|---|
| Variable | SAMAX <code> |
| Valid Values | 0 or 1 |
| Default Value | 0 |
| Data Type | Integer |
| Description | When set to 1, enables output of the maximum value of each enabled channel measured in the current accumulated data. This data is output as Scan Group 3 in the output data file. |

SAMIN

| | |
|---------------|---|
| Variable | SAMIN <code> |
| Valid Values | 0 or 1 |
| Default Value | 0 |
| Data Type | Integer |
| Description | When set to 1, enables the output of the minimum value of each enabled channel measured in the current accumulated data. This data is output as Scan Group 4 in the output data file. |

SARMS

| | |
|---------------|--|
| Variable | SARMS <code> |
| Valid Values | 0 or 1 |
| Default Value | 0 |
| Data Type | Integer |
| Description | When set to 1, enables the output of the Root Mean Square value of each enabled channel calculated from the current accumulated data. This data is output as Scan Group 5 in the output data file. |

SASDEV

| | |
|---------------|---|
| Variable | SASDEV <code> |
| Valid Values | 0 or 1 |
| Default Value | 0 |
| Data Type | Integer |
| Description | When set to 1, enables the output of the calculated standard deviation of each enabled channel calculated from the current accumulated data. This data is output at Scan Group 6 in the output data file. |

SAAVGXO

| | |
|---------------|--|
| Variable | SAAVGXO <code> |
| Valid Values | 0 or 1 |
| Default Value | 0 |
| Data Type | Integer |
| Description | When set to 1, enables the output of the rolling average of each enabled channel calculated in the current accumulated data with the outliers and overloads excluded. This data is output as Scan Group 7 in the output data file. |

SAOL

| | |
|---------------|---|
| Variable | SAOL <code> |
| Valid Values | 0 or 1 |
| Default Value | 0 |
| Data Type | Integer |
| Description | When set to 1, enables the output of the number of overloads measured and excluded from the current accumulated data for each enabled channel. This data is output as Scan Group 8 in the output data file. |

READMODE

| | |
|---------------|--|
| Variable | READMODE <code> |
| Valid Values | 0 or 1 |
| Default Value | 0 |
| Data Type | Integer |
| Description | <p>When set to 1, Enables the READMODE function. READMODE will only function when the following configuration variables are set::</p> <ul style="list-style-type: none">SET SA 1SET EU 1SET ADTRIG 0SET AVG1 1SET FPS1 0 <p>When READMODE is enabled along with the RTDA functions, a SCAN command will initiate data collection and RTDA. No data will be output until a READ command, or ? Is issued to the ERAD4000. At that time a "snapshot" frame of data will be acquired and output. If BIN is set to 0, Data will be output to the TELNET port or the NAS in ASCII. If BIN is set to 1, Data will be output to the NAS in binary.</p> |

SYSLOG VARIABLES (GROUP SYSLOG)***ENYSYSLOG***

| | |
|---------------|---|
| Variable | ENYSYSLOG <code> |
| Valid Values | 0 or 1 |
| Default Value | 0 |
| Data Type | Integer |
| Description | This enables or disables the output to the Syslog server. |

LEVEL

| | | | | | | | | | | | | | | | | | |
|---------------|---|---------|----------|-------|-------|------|--------|------|--------|------|--------|------|---------|--------|------|-----|---------|
| Variable | LEVEL <code> | | | | | | | | | | | | | | | | |
| Valid Values | 0 through 7 | | | | | | | | | | | | | | | | |
| Default Value | 3 | | | | | | | | | | | | | | | | |
| Data Type | Integer | | | | | | | | | | | | | | | | |
| Description | <p>This sets the level of error severity that is sent out. Any error with severity above this number is not sent (where 0 is the most severe and 7 is the least severe). Severity codes are assigned per RFC3164 specification.</p> <p>All errors in the ERAD4000 are severity level 3 at this time.</p> <p>Each message has a TAG section and a CONTENT section per RFC3164. The TAG returns the current mode of the RAD in string form. The possible values are:</p> <table> <tr> <td>STARTUP</td> <td>IDPWRITE</td> </tr> <tr> <td>READY</td> <td>PURGE</td> </tr> <tr> <td>SCAN</td> <td>FORMAT</td> </tr> <tr> <td>CALZ</td> <td>SAVEIP</td> </tr> <tr> <td>EXIT</td> <td>A2DCAL</td> </tr> <tr> <td>LIST</td> <td>A2DTCAL</td> </tr> <tr> <td>UPLOAD</td> <td>SAVE</td> </tr> <tr> <td>CAL</td> <td>UNKNOWN</td> </tr> </table> | STARTUP | IDPWRITE | READY | PURGE | SCAN | FORMAT | CALZ | SAVEIP | EXIT | A2DCAL | LIST | A2DTCAL | UPLOAD | SAVE | CAL | UNKNOWN |
| STARTUP | IDPWRITE | | | | | | | | | | | | | | | | |
| READY | PURGE | | | | | | | | | | | | | | | | |
| SCAN | FORMAT | | | | | | | | | | | | | | | | |
| CALZ | SAVEIP | | | | | | | | | | | | | | | | |
| EXIT | A2DCAL | | | | | | | | | | | | | | | | |
| LIST | A2DTCAL | | | | | | | | | | | | | | | | |
| UPLOAD | SAVE | | | | | | | | | | | | | | | | |
| CAL | UNKNOWN | | | | | | | | | | | | | | | | |

IPSYSLOG

| | |
|---------------|--|
| Variable | IPSYSLOG <code> |
| Valid Values | Any valid IP address |
| Default Value | 10.0.0.1 |
| Data Type | Integer |
| Description | This sets the IP address of the Syslog server. Syslog messages are sent via UDP and adhere to the RFC3164 specification. |

ERAD4000 ID CHIP DATA FORMAT

The ERAD4000 system uses the Dallas DS2430A EEPROM chip for storing information about various system components. The information travels with the hardware, allowing the system to configure itself after power-up. The DS2430A has two memory areas; a 64 bit permanent memory that is written once during the manufacturing, and a 256 bit area that can be written multiple times.

The permanent memory area will contain information necessary to identify the device in a format that is consistent over all of our device types. The 256 bit memory area will have a device dependent format.

PERMANENT MEMORY DATA FORMAT

The permanent memory area contains a Device Family Code, a Device Model Code, a Serial Number, a Revision Code, and a Manufacture Date.

| Permanent Memory 64 Bits | | | |
|--------------------------|-------|--------------------|--|
| Bits | Name | Description | Assigned Values |
| 4 | DFC | Device Family Code | 0 = ERAD Temperature A/D board 1 = ERAD Pressure A/D board 2 = Pressure Scanner Module 3 = ERAD Digital I/O Device 4 = Test Fixture 5 = Voltage Scanner Module |
| 4 | DMC | Device Module Code | Family Code = 0 0 = 16 Bit 100 KHz, 5V Ref., Gain = 2.852 Family Code = 1 0 = 16 Bit 100 KHz Family Code = 2 0 = ZOC 3016 1 = ZOC 17 2 = ZOC 22 3 = ZOC 23 4 = ZOC 33 Family Code = 3 0 = RDS Remote Digital Switch, 8 Channels Family Code = 4 0 = BASM3200 Family Code = 5 0 = ZOC16EIM 1 = ZOCEIM16 2 = ZOCEIM32 |
| 12 | SN | Serial Number | Binary Number 0 - 4096 |
| 4 | REV | Revision | Letter Code A - P |
| 16 | MDATE | Manufacture Date | DDDDMMMMYYYYYY DDDD = Day (1 - 31) MMMM = Month (1 - 12) YYYYYY = Years past 2000 (0-128) |
| 24 | | Spare | |

EEPROM MEMORY DATA FORMAT

The EEPROM data format is device dependent. The five device families are listed in the following tables.

| ERAD4000 Temperature A/D Board (Device Family = 0) EEPROM Memory 256 Bits | | | |
|--|---------|------------------------------|--|
| Bits | Name | Description | Assigned values |
| 32 | ADCA | A/D Correction Coefficient A | The A coefficient for Ax^2+Bx+C . 32 bit floating point coefficients. |
| 32 | ADCB | A/D Correction Coefficient B | The B coefficient for Ax^2+Bx+C . 32 bit floating point coefficients. |
| 32 | ADCC | A/D Correction Coefficient C | The C coefficient for Ax^2+Bx+C . 32 bit floating point coefficients. |
| 32 | RV | Reference Voltage | 32 bit floating point number equals measured output of voltage reference. |
| 16 | ACDATE | A/D Calibration Date | DDDDMMMMYYYYYYY DDDD = Day (1-31) MMMM= Month (1-12) YYYYYYY= Years past 2000 (0-128) |
| 12 | SN | ERAD Serial Number | Binary Number 0-4096 |
| 8 | APPTYPE | ERAD Application | Integer, Binary Number 0 - 255 0 = Standalone (default) 1= ERAD4000 |
| 92 | | SPARE | |

| ERAD4000 Pressure A/D Board (Device Family = 1) EEPROM Memory 256 Bits | | | |
|---|--------|-------------------------------|--|
| Bits | Name | Description | Assigned values |
| 32 | ADCA | A/D Correction Coefficient A | The A coefficient for Ax^2+Bx+C . 32 bit floating point coefficients. |
| 32 | ADCB | A/D Correction Coefficient B | The B coefficient for Ax^2+Bx+C . 32 bit floating point coefficients. |
| 32 | ADCC | A/D Correction Coefficient C | The C coefficient for Ax^2+Bx+C . 32 bit floating point coefficients. |
| 32 | ECC | Excitation Current Correction | 32 bit floating point number equals deviation from 1.5 mA ideal with exact 5 V reference. |
| 16 | ACDATE | A/D Calibration Date | DDDDMMMMYYYYYYY DDDD = Day (1-31) MMMM= Month (1-12) YYYYYYY= Years past 2000 (0-128) |
| 8 | GAIN | Gain Code | 0 = 2.852 Gain |
| 104 | | SPARE | |

| Pressure Scanner Module (Device Family = 2) EEPROM Memory 256 Bits | | | |
|---|--------|----------------------------------|---|
| Bits | Name | Description | Assigned Values |
| 8 | RTYPE | RTD Type Code | 0 = Platinum 385 1 = Nickel-Iron |
| 8 | RVALUE | RTD Value Code | RTD Type Code = 0 0 = 100Ω 1 = 500Ω 2 = 1000Ω RTD Type Code = 1 0 = 604Ω |
| 32 | RCORA | RTD Correction A | A term for Callendar-Van Dusen equation. 32 bit floating point number. |
| 32 | RCORB | RTD Correction B | B term for Callendar-Van Dusen equation. 32 bit floating point number. |
| 16 | RCDATE | RTD Calibration Date | DDDDMMYYYY DDDD = Day (1 – 31) MMMM = Month (1 – 12) YYYYYY = Years Past 2000 (0 – 128) |
| 16 | PCDATE | Pressure Sensor Calibration Date | DDDDMMYYYY DDDD = Day (1 – 31) MMMM = Month (1 – 12) YYYYYY = Years Past 2000 (0 – 128) |
| 32 | NPR1 | Nominal Pressure Range 1 | 32 Bit Floating Point Number, units of PSI |
| 32 | NPR2 | Nominal Pressure Range 2 | 32 Bit Floating Point Number, units of PSI |
| 8 | VALVE | Pressure Valve Arrangement | 0 = None 1 = X1 2 = X2 3 = NPX 4 = NO 5 = IP |
| 8 | XDUCER | Transducer Type | 0 = Differential 1 = Absolute 2 = Gauge 3 = True Delta P 4 = EIM |
| 64 | | SPARE | |
| RAD4000 Digital I/O Device (Device Family = 3) EEPROM Memory 256 Bits | | | |
| Bits | Name | Description | Assigned Values |
| 256 | | Not Used | |
| Test Fixture (Device Family = 4) EEPROM Memory 256 Bits | | | |
| Bits | Name | Description | Assigned Values |
| 256 | | Not Used | |
| Voltage Scanner (Device Family = 5) EEPROM Memory 256 Bits | | | |
| Bits | Name | Description | Assigned values |
| 256 | | Not Used | |

NETWORK ATTACHED STORAGE (NAS) OPERATION

When the variable: ENNAS is set to 1 or 2, all ASCII or BINARY data are directed to the NAS via FTP. Binary files will have the extension: .BIN. ASCII files will have the extension: .TXT.

The setting of ENNAS will determine the construction of the file name. When ENNAS is set to 1, a sequence number is used to construct the file name. For Binary (BIN = 1), the file name will be the file name prefix as set by the variable: FILENAS and a sequence number set by the software. The format is:

<file name prefix>_SSSS.BIN

For ASCII (BIN = 0), the file name will be the file name prefix as set by the variable: FILENAS and a sequence number set by the software. The format is:

<file name prefix>_SSSS.TXT

The sequence number is maintained in the ERAD4000 and saved to a file named: SSN,CFG. The save to SSN.CFG is automatic and not part of the SAVE command group. This file is maintained on the Micro SD. If this file is not found the sequence will start at 0000.

NAS SETUP FOR USE WITH A ERAD4000

When a NAS is used with a ERAD4000, it must be set up as a FTP Server. A user must consult the documentation for the NAS being used to ensure proper operation.

LOCAL HOST COMPUTER SETUP AS A NAS

A local/ host computer, such as a laptop, may be used as a NAS for high speed data storage. In order for the data to be transferred, the computer must be set up as a FTP server. FTP Server software, such as FileZilla, must be set up and running before a SCAN command is issued.

DUAL TELNET INFORMATION

The ERAD4000 has two hardware sockets reserved for Telnet communications. When the ERAD is supporting one ESTABLISHED Telnet session, and it receives a connection request on the second socket, it will accept the second connection and send a TCP keep-alive packet to the client host of the first connection. If the ERAD receives an ACK for the keep-alive packet on the first connection, then both sessions will be supported simultaneously. If no ACK is received from the host on the first connection, the ERAD will close the socket and it will reopen in LISTENING state.

Most implementations of the TCP protocol support ACKs for keep-alive packets, see Section 4.2.3.6 of RFC 1122 for more information.

NOTE: The dual Telnet feature on the ERAD is designed to be used for short debugging sessions or for recovering from TCP half-closed connections. In order to recover from a TCP half-closed connection, the ERAD must have one open TELNET socket in LISTENING state. It is up to the client TCP implementation to ensure that this is the normal state by properly closing the connection when it is finished communicating with the ERAD. **The ERAD can only send scan data to one host, and cannot send data to both Telnet sockets simultaneously.**

SCANIVALVE DSP BOOT LOADER

The Scanivalve DSP Boot Loader's main function is to allow the user to easily upload the ERAD4000 application via FTP. The boot loader runs the FTP server. It has been tested on Fire Fox FTP and Internet Explorer drag and drop.

Any additional file transfer protocols or additional FTP client support modification will be made solely to the application.

FTP

The FTP server supports the following FTP commands prior to login:

- USER Allows the user to enter the user's name. Anonymous is allowed.
- PASS Allows the user to enter the password.
- QUIT Disconnects from the FTP server.

The FTP server supports the following FTP commands prior to login after login:

- RETR Initiates a file transfer from the ERAD4000 to the host.
- STOR Initiates a file transfer from the host to the ERAD4000.
- PASV Sets up data port so client can connect to server's port.
- LIST Returns a directory listing of the files stored on the ERAD4000
- SIZE Returns the size in bytes of the file.
- DELE Deletes the file.
- NOOP No operation. Mostly used by the client as an "are you still there" command.

Only ASCII type of transfer is supported. Only passive data connection is supported. This allows data to be transferred without the server initiating a connection to the client. This could cause firewall problems.

BOOT LOADER AND APPLICATION FILE SYSTEM

Filenames are limited to the 8.3 format with no spaces allowed. Only one drive is supported.

Because the ERAD4000 does not have a time and date clock all files created by the ERAD will have a date of Aug 8, 2008.

No Subdirectories are supported, however, if a file path is included in the file specification only the file name portion is used. The file is written in the root directory of the above drive.

Up to 1024 Files are allowed or 2GB of data.

DIP SWITCH SETTINGS

The processor board has 4 DIP switches that affect the operation of the software. These switches are only read at power up. Changes to the dip switches are not effective until the power is cycled.

- SW1 When this switch is on automatically boots the application on power up.
- SW2 When this switch is on the boot loader will run in the debug mode. Debug output is directed to the COM2 serial port.
- SW3 When this switch is on the boot loader and application uses the COM2 serial port for communication to other devices. When this switch is off the COM2 serial port is used as host communication. COM1 is only used for device communication. COM1 is the top serial connection.
- SW4 Spare

HOST COMMUNICATION

Commands are issued to the ERAD and response is returned from the ERAD via either the serial port or the Ethernet connector. The boot loader returns the command information to the host that it received its command. That is, when the command is received from the network it is returned to the network. When it is received from the serial port it is returned to serial port.

The network supports TCP/IP connection using Telnet or HyperTerminal.

COMMANDS

When a command is completed, the prompt character, the greater than character ">", is output preceded by a carriage return and line feed.

The commands listed below are supported by the boot loader and the executable program, unless otherwise noted. They may be viewed and modified in the ERAD4000 executable program.

| | |
|-----------------------|--|
| VER | Returns the Version of the Boot loader NOTE: This command is available in the boot loader only. It must not be confused with the VER command in the application. |
| FORMAT | Formats the SD Flash to all 0's NOTE: This command is available in the boot loader only. |
| LIST IP | Returns the configuration variable settings of the IP group |
| SET <parameter> | Sets the indicated parameter |
| IPADD<IP Address> | Sets the IP address of the ERAD. If IPADD is changed, the power must be cycled to take effect. |
| SUBNET <mask> | Sets the subnet address of the ERAD4000. If SUBNET is changed, the power must be cycled to take effect. |
| MAC <MAC Address> | Sets the MAC address for the ERAD4000. If MAC is changed, the power must be cycled to take effect. NOTE: This variable should not be modified |
| LOGIN <user name> | Sets the user name for FTP login. |
| PASSWORD <password> | Sets the password associated for LOGIN. |
| LOGIN1 <user name> | Sets the user name 1 for FTP login. |
| PASSWORD1<password> | Sets the Password associated for LOGIN1. |
| LOGINNAS <name> | Sets the name for login to the NAS. The boot loader does not access the NAS device. This is placed in this group for compatibility with the IP group application. |
| PASSWORDNAS<password> | Sets the password associated with LOGINNAS. |
| IPADDNAS <IP address> | Sets the IP address of the NAS |
| APP <app file name> | Sets the file name of the application to run. This is the file name that is used when automatically running the application from the boot loader. It is also the file name used when using the RUN command. When this file is not found the application does not run and an error is returned. |

| | |
|--------------------|--|
| SAVE [<file name>] | Saves the configuration variables to the working directory. When an optional file name is entered, it saves the IP group settings to that file name. |
| TYPE <file name> | Lists the contents of the named file |
| LOAD <file name> | Loads the named file into the LIST IP configuration variables. NOTE: This command is a debug command. |
| DIR | Lists the files on the SD card. |
| DEL <file name> | Deletes the file name |
| DIP | Reads and shows the settings of the DIP switch. The following is returned: DIP settings Auto Run Application 0 Debug 0 No Serial Host 0 Spare 0 1 indicates on, 0 indicates off NOTE: This command is available in the boot loader only. |
| RUN | Runs the application named in the SET APP setting. NOTE: This command is available in the boot loader only. |

ERAD4000 SCAN FUNCTION

When a SCAN function is initiated, the ERAD4000 will scan all of the channels in the modules enabled in the software. All modules are scanned in parallel. Each channel in a module will be accessed at the rate set in the configuration variable, PERIOD. Data from each channel are accumulated in a buffer until the AVG term is met. The data from each channel are averaged and then output as a FRAME. This process will continue until the number of frames set in the variable, FPS, have been output, or a STOP command is received.. When FPS has been met, or a STOP command received, the Scan function will stop and the ERAD4000 will return to the READY mode. If FPS is set to 0(zero), the SCAN function will continue indefinitely until a STOP command is received. A STOP Command may be entered by typing STOP from the Local or remote keyboard, or by pressing the Escape Key on either input.

Two configuration variables, ADTRIG and SCANTRIG, determine how the SCAN function will be implemented.

INTERNAL TRIGGER

When these variables are set to 0 (disabled), the SCAN function will be controlled by an internal clock trigger. The SCAN function will be initiated by a SCAN command issued from the ERAD4000 computer or an external Host computer. Scanning will commence approximately 5 milliseconds after the SCAN command is received. Each Frame will be acquired as soon as the previous Frame acquisition is complete. The SCAN function will remain active until FPS is met or a STOP Command is received.

EXTERNAL TRIGGER

The ERAD4000 SCAN function may be controlled with external triggers. The settings of SCANTRIG and ADTRIG determine how the SCAN function will be initiated and how each Frame will be acquired. ADTRIG and SCANTRIG cannot be enabled at the same time.

When ADTRIG is set to 1(enabled), the SCAN function will be initiated by the SCAN command. The ERAD4000 will enter the SCAN mode and wait for a hardware or software trigger. When a trigger is received, the ERAD4000 will acquire and output one averaged Frame of data and re-enter the WTRIG mode. Multiple trigger pulses received during a Frame Scan will be ignored. When a frame has been output, the next trigger will repeat the process. This will continue until the Frames per Scan Variable has been satisfied or a STOP command is received. If ADTRIG is set to 1, SCANTRIG must be set to 0.

When SCANTRIG is set to 1(enabled), the SCAN function will be initiated by the DINSCAN digital input. When a hardware trigger is received, the RAD4000 will enter the SCAN mode, acquire and output averaged Frames of data until the Frames per Scan Variable has been satisfied or a STOP command is received. Multiple trigger pulses received after the first trigger will be ignored. When Frames per Scan has been satisfied, the RAD4000 will exit the SCAN mode and return to the READY mode. Another hardware trigger will repeat the process. A software trigger will not initiate this process. If SCANTRIG is set to 1, ADTRIG must be set to 0.

HARDWARE TRIGGER

The Hardware Trigger input is optically isolated to prevent grounding problems. It is a TTL level, edge sensing device. It requires a minimum signal of 9 Vdc @ 6.5 mA. It may accept voltages as high as 15 Vdc. The external trigger input is on pins 8 and 9 of the ERAD4000 Power input connector.

SOFTWARE TRIGGER

The Software Trigger is a <TAB> character, or Ctrl I, or the TRIG command.

ERAD4000 DATA SELECTION CHART

This chart shows all valid data setups for versions 2.00 and higher.

| Data Destination | Data Type | RTDA | Packet Type | Trig | ENNAS | EU | SA | BIN | FORMAT | ADTRIG | BINADDR | | |
|-------------------------------|---------------|----------|-------------|--------|-------|-----|----|-----|--------|--------|---------|----|---|
| NAS Date/ Time FileName | Pressure | Yes | Binary | Int | 2 | 1 | 1 | 1 | X | 0 | X | | |
| | | | ASCII | Int | 2 | 1 | 1 | 0 | 0 | 0 | 0 | X | |
| | | No | Binary | Int | 2 | 1 | 0 | 1 | X | 0 | 0 | X | |
| | | | | Ext | 2 | 1 | 0 | 1 | X | 1 | 1 | X | |
| | | | ASCII | Int | 2 | 1 | 0 | 0 | 0 | 0 | 0 | 0 | X |
| | | | | Ext | 2 | 1 | 0 | 0 | 0 | 0 | 1 | 1 | X |
| | Counts | No | Binary | Int | 2 | 0 | X | 1 | X | 0 | 0 | X | |
| | | | | Ext | 2 | 0 | 0 | 1 | X | 1 | 1 | X | |
| | | | ASCII | Int | 2 | 0 | X | 0 | 0 | 0 | 0 | 0 | X |
| | | | | Ext | 2 | 0 | 0 | 0 | 0 | 0 | 1 | 1 | X |
| NAS Sequence FileName | Pressure | Yes | Binary | Int | 1 | 1 | 1 | 1 | X | 0 | X | | |
| | | | ASCII | Int | 1 | 1 | 1 | 0 | 0 | 0 | 0 | X | |
| | | No | Binary | Int | 1 | 1 | 0 | 1 | X | 0 | 0 | X | |
| | | | | Ext | 1 | 1 | 0 | 1 | X | 1 | 1 | X | |
| | | | ASCII | Int | 1 | 1 | 0 | 0 | 0 | 0 | 0 | 0 | X |
| | | | | Ext | 1 | 1 | 0 | 0 | 0 | 0 | 1 | 1 | X |
| | Counts | No | Binary | Int | 1 | 0 | X | 1 | X | 0 | 0 | X | |
| | | | | Ext | 1 | 0 | 0 | 1 | X | 1 | 1 | X | |
| | | | ASCII | Int | 1 | 0 | X | 0 | 0 | 0 | 0 | 0 | X |
| | | | | Ext | 1 | 0 | 0 | 0 | 0 | 0 | 1 | 1 | X |
| UDP | Pressure | Yes | Binary | Int | 0 | 1 | 1 | 1 | X | 0 | >0 | | |
| | | No | | Int | 0 | 1 | 0 | 1 | X | 0 | >0 | | |
| | | | | Ext | 0 | 1 | 0 | 1 | X | 1 | >0 | | |
| | | Counts | | No | Int | 0 | 0 | X | 1 | X | 0 | >0 | |
| | Ext | | | | 0 | 0 | 0 | 1 | X | 1 | >0 | | |
| | TCP Telnet | Pressure | | Yes | ASCII | Int | 0 | 1 | 1 | 0 | 0 | 0 | X |
| No | | | Int | 0 | | 1 | 0 | 0 | 0 | 0 | 0 | X | |
| | | | Ext | 0 | | 1 | 0 | 0 | 0 | 1 | 1 | X | |
| | | | Int | 0 | | 1 | 0 | 0 | 1 | 0 | 0 | X | |
| | | | Ext | 0 | | 1 | 0 | 0 | 1 | 1 | 1 | X | |
| Counts | | | No | Int | | 0 | 0 | X | 0 | 0 | 0 | 0 | X |
| | | Ext | | 0 | | 0 | 0 | 0 | 0 | 1 | 1 | X | |
| | | Int | | 0 | | 0 | X | 0 | 1 | 0 | 0 | X | |
| | | Ext | | 0 | | 0 | 0 | 0 | 1 | 1 | 1 | X | |
| TCP Binary | | Pressure | No | Binary | | Int | X | 1 | 0 | 1 | 0 | 0 | 0 |
| | Ext | | | | X | 1 | 0 | 1 | 0 | 1 | 0 | | |
| | Counts | No | Int | | X | 0 | 0 | 1 | 0 | 0 | 0 | | |
| | | | Ext | | X | 0 | 0 | 1 | 0 | 1 | 0 | | |

NOTES FOR DATA SELECTION CHART

1. An error will be issued if a combination not listed above is selected.
2. An error will be issued if NAS Date-Time is selected and a NTP server is not found.
3. The ERAD will not SCAN in a non-valid combination.
4. When RTDA is enabled, AVG1 will be forced to 1 regardless of the setting.
5. An error will be issued if the channel list is empty.
6. ZC should be set to 1, except during troubleshooting
7. An error will be issued if SA is set to 1 and ADTRIG is set to 1.
8. The host computer firewall must be set to permit the NTP to work correctly.
9. An error will be issued if READMODE is set to 1, SA is set to 1, and FPS is not set to 0.
10. An X indicates that the setting may be any valid setting for that parameter.

ERAD4000 PROFILE FILE

When the RAD4000.EXE program is started, including a RESTART, a ERAD4000 Profile file will be generated. This file is named RAD4000nnn.DPF, where nnn is the serial number of the ERAD4000. This file is an ASCII text file and contains the following information:

```

RAD4000 Serial Number: <serial number><CR><LF>
Module Serial Number in Position 1: <module serial number><CR><LF>
Module Serial Number in Position 2 <module serial number><CR><LF>
Module Serial Number in Position 3: <module serial number><CR><LF>
Module Serial Number in Position 4: <module serial number><CR><LF>
Module Serial Number in Position 5: <module serial number><CR><LF>
Module Serial Number in Position 6: <module serial number><CR><LF>
Module Serial Number in Position 7: <module serial number><CR><LF>
Module Serial Number in Position 8: <module serial number><CR><LF>

```

If a RAD4000nnn.DPF file exists when the RAD4000.EXE program starts up, it will be overwritten by the information obtained from the polling of the ID chips.

MODULE PROFILE FILE

Each module has a unique Module Profile File which is created during the initial calibration of the module. This file is updated each time a SAVE command is executed by the ERAD4000. These files are read when the RAD4000.EXE program is started, including RESTART. The information contained in the Module Profile File is:

```

REMn 1 <comment><CR><LF>
REMn 2 <comment><CR><LF>
REMn 3 <comment><CR><LF>
REMn 4 <comment><CR><LF>
SET TYPEn <module type><CR><LF>
SET NUMPORTSn <number of ports><CR><LF>
SET NPRn <Nominal Full Scale Pressure Value><CR><LF>
SET TEMPMn <temperature gain factor><CR><LF>
SET TEMPBn <temperature offset factor><CR><LF>
SET LPRESSn <channels> <pressure><CR><LF>
SET HPRESSn <channels> <pressure><CR><LF>
SET NEGPTSn <channels> <number of negative points><CR><LF>
INSERT <temperature> <channels> <pressure> <pressure counts> M<CR><LF>
INSERT <temperature> <channels> <pressure> <pressure counts> M<CR><LF>
:
:
INSERT <temperature> <channels> <pressure> <pressure counts> M<CR><LF>

```

BINARY SCAN PACKETS**TABLE 1: BINARY SCAN PACKET**

| Function Description | Bytes | Data Type | Value | Notes |
|--------------------------------|------------------|------------------|----------------------|-----------------------------|
| Binary ID | 1 | Byte | 1 or 2 | 1 = EU, 2 = Raw |
| Group ID | 1 | Byte | 1 to 8 (or 81 to 88) | |
| Number of Channels | 2 | Short | 0 to 512 | |
| Frame Number | 4 | Unsigned Integer | 1 to 2 ³² | |
| Time | 4 | Unsigned Integer | 0 to 2 ³² | Frame time in ms or μ s |
| Channel Data [Num Channels] | See Table 2 or 3 | | | |

TABLE 2: CHANNEL DATA (BIN == 1 OR BIN == 4, SINGLE CHANNEL SHOWN)

| Function Description | Bytes | Data Type | Value | Notes |
|----------------------|-------|------------------|-------|-----------------------------|
| Pressure | 4 | Float or Integer | | Float if EU, Integer if RAW |

TABLE 3: CHANNEL DATA (BIN == 2, SINGLE CHANNEL SHOWN)

| Function Description | Bytes | Data Type | Value | Notes |
|----------------------|-------|------------------|-------------------------|-----------------------------|
| Pressure | 4 | Float or Integer | | Float if EU, Integer if Raw |
| Module Number | 2 | Short | 1 to 8 | |
| Port Number | 2 | Short | 1 to Number of Channels | |

TABLE 4: BINARY SCAN HEADER PACKET (BIN == 4 ONLY, ONE PACKET AT START OF SCAN)

| Function Description | Bytes | Data Type | Value | Notes |
|-----------------------------|-------|---------------------|------------|---|
| Header Size | 2 | Short | 136 | Total header packet size in bytes (136) |
| Sample Date | 10 | Char | MM/DD/YYYY | ASCII encoded date |
| Sample Time | 8 | Char | hh:mm:ss | ASCII encoded time |
| Frames Per Scan | 32 | Unsigned Integer[8] | | FPS(g), 4 bytes per scan group g |
| Average | 16 | Short[8] | | AVG(g), 2 bytes per scan group g |
| Num Channels Per Scan Group | 16 | Short[8] | | nChan(g), 2 bytes per scan group g |
| Period | 4 | Unsigned Integer | | |
| ADTRIG | 2 | Short | | |
| A2DCOR | 2 | Short | | |
| CVTUNITS | 4 | Float | | |
| MAXEU | 4 | Float | | |
| MINEU | 4 | Float | | |
| Module SN | 16 | Short[8] | | SN(m), 2 bytes per module (m) |
| Num Channels Per Module | 16 | Short[8] | | nChan(m), 2 bytes per module (m) |

NOTE: This binary packet is not supported in Versions 1.00 through 2.01

When BIN is set to 1 and the BINADDR is set to a value other than zero, the data from the AUX or CAL commands are converted to a BINARY format and output over the UDP binary port specified in the BINADDR variable. The data format is:

<ID byte> - 1 byte, the value will be 1 if the data are from a calibrator or 2 if the data are from an auxiliary unit.

<pressure> - 4 bytes of floating point binary pressure data

ASCII DATA TRANSFER

| Function Description | Bytes | Data Type | Value |
|--|--------|-----------|--|
| ASCII Data (The first two bytes must NOT be 1Hex through 9Hex). Refer to the Command section of this manual for the proper command return formats. | Varies | String | Unique to packet. Each line is terminated with a CR, LF, CR-LF, or LF-CR. |

EXAMPLES:

The following shows the format of the ASCII DATA portion of the List Packet in response to a LIST MASTER:

```
INSERT <temp> <chan> <press> <press counts> /M
INSERT <temp> <chan> <press> <press counts> /M
:      :      :      :      :
INSERT <temp> <chan> <press> <press counts> /M
```

When a LIST ALL is commanded, Master and Calculated planes are listed. The Master items will have a /M suffix while the Calculated items will have a /C. The following is an example of a LIST ALL command:

```
INSERT <temp> <chan> <press> <press counts>/M
INSERT <temp> <chan> <press> <press counts>/C
:::
INSERT <temp> <chan> <press> <press counts>/M
```

For examples of the ASCII packets returned from a SCAN command, refer to the SCAN command.

This page is intentionally left blank

APPENDIX A - TEMPERATURE COMPENSATED PRESSURE CONVERSION

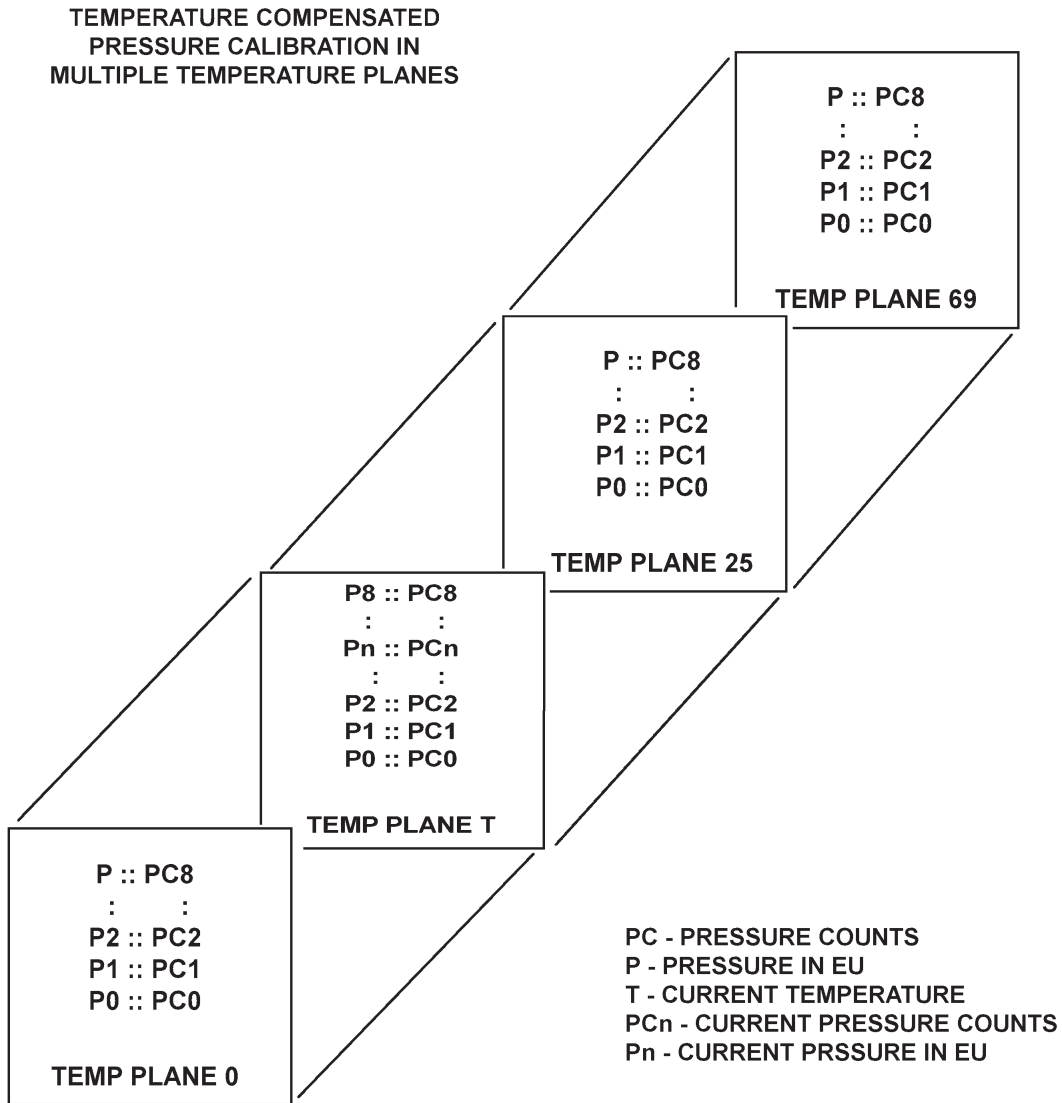

FORMULAS:

Pressure interpolation within current temperature plane:

$$P_{nt} = \frac{1}{PC_{1t} - PC_{0t}} ((PC_{1t} - PC_{nt})P_{0t} - (PC_{0t} - PC_{nt})P_{1t})$$

Calculation of entries in current temperature plane:

$$P_{t=} \frac{1}{T_{25} - T_0} ((T_{25} - T) P_{00} - (T_0 - T) P_{025})$$

APPENDIX B - ENGINEERING UNIT CONVERSION CONSTANTS

| UNITSCAN Setting | Engineering Unit | PSI to EU 1 psi = | EU to PSI 1 EU = |
|------------------|--------------------------------|------------------------------|---------------------|
| ATM | Atmospheres | 0.068046A | 14.6960 psi |
| BAR | Bars | 0.068947 b | 14.5039 psi |
| CMHG | Centimeters of Mercury | 5.17149 cmHg | 0.193368 psi |
| CMH2O | Centimeters of Water | 70.308 cmH ₂ O | 0.014223 psi |
| DECIBAR | Decibar | 0.68947 db | 1.4504 psi |
| FTH2O | Foot of Water | 2.3067 ftH ₂ O | 0.43352 psi |
| GCM2 | Gram per square Centimeter | 70.306 g/cm ² | 0.014424 psi |
| INHG | Inch of Mercury at 0°C | 2.0360 inHg | 0.491159 psi |
| INH2O | Inch of Water at 4°C | 27.680 in H ₂ O | 0.036127 psi |
| KGCM2 | Kilogram per square Centimeter | 0.0703070 kg/cm ² | 14.2235 psi |
| KGM2 | Kilogram per square Meter | 703.070 kg/m ² | 0.0014223 psi |
| KIPIN2 | kips per square inch | 0.001 kip/in ² | 1000.0 psi |
| KNM2 | Kilonewton per square Meter | 6.89476 kN/m ² | 0.145038 psi |
| KPA | Kilopascal | 6.89476 kPa | 0.145038 psi |
| MBAR | Millibar | 68.947 mb | 0.014504 psi |
| MH2O | Meter of Water | 0.70309 mH ₂ O | 1.42229 psi |
| MMHG | Millimeter of Mercury | 51.7149 mmHg | 0.0193368 psi |
| MPA | Megapascal | 0.00689476 MPa | 145.038 psi |
| NCM2 | Newton per square Centimeter | 0.689476 N/cm ² | 1.45038 psi |
| NM2 | Newton per square meter | 6894.76 N/m ² | 0.000145038 psi |
| OZFT2 | Ounce per square Foot | 2304.00 oz/ft ² | 0.000434028 psi |
| OZIN2 | Ounce per square Inch | 16.00 oz/ft ² | 0.062500 psi |
| PA | Pascal | 6894.76 Pa | 0.000145038 psi |
| PSF | Pound per square Foot | 144.00 lb/ft ² | 0.00694444 psi |
| TORR | Torr | 51.7149 T | 0.0193368 psi |

APPENDIX C - SOFTWARE CHANGE LOG

This section contains change information to assist a user in determining the differences between different versions of software.

Version 1.00 - February 2010

First release.

Version 1.01 - March 2010

Corrected minor bugs in

TGRAD

A2DCALC

IDPWRITE

Version 1.02 - Not Released

Version 1.03 - April 2010

Corrected bugs in the following variables to improve reliability and accuracy.

TGRAD

CALZ

Corrected a bug in the conversion calculation that caused errors near zero

Version 1.04 - June 2010

Corrected a bug in the external frame trigger

Corrected timing issues to insure 625 samples/channel/second

Corrected an error in the data for all channel ones in Frame 1

Added support of MODTEMP

Added support of the ERROR buffer

Added support of IFUSER

Added support of the CLEAR command

Modified the method of setting the value of CALPER

Version 2.00 - November 2010

Added Real Time Data Analysis Group

Added support of a second TCP socket. If a second socket is opened, the original socket will be dropped.

Version 2.01 - April 2011

Corrected a bug in the calculation of the MPBS variable.

Corrected a bug in the A/D temp calculation for temperatures below 0 degrees C

Corrected a bug that prevented the use of Filezilla as the FTP server for NAS operation

Added a Binary Scan Header.

Corrected several bugs in error reporting based on the setting of ENNTP and ENNAS.

Increased number of temperature planes to 22

Load CV.GPF file before MPF files to insure correct MPBS value

Version 2.02 - June 2011

Corrected several compatibility issues between RAD4000 and RAD3200

LOGIN commands will not cause errors

SET FILEOUT will not cause errors

Added Commands

BLVER

CLEARERROR

FILE

GETERROR

SAVE CV

Enabled MODTEMP

Enabled binary packets 3 and 4

Corrected a bug in the Time Stamp output

Improved the External Trigger function when data output is set to Binary

Corrected a bug in CALZ that offset the value of the first scanned channel at Periods faster than 50 microseconds.

Added Rename capability to the FTP operation. Files on the Micro SD card may now be renamed.

Improved ASCII data transfer rate.

Version 2.03 - June 2011

Corrected a bug in the LIST SYS command. The data from this command was being returned twice.

Version 2.04 - July 2011

Corrected a bug in the CALINS software module

Added a switch to the term FILENAS that, when set to 1, will lock the file sequence number at 0000.

When the switch is set to 0, the sequence number will increment with each successive scan.

Added a FTP server connection retry error to the GETERROR counter.

Corrected the definition of Period in the binary scan header.

Corrected the module channel definition in the binary scan header.

Version 2.05 - May 2012

Added the A2DTCAL, A2DTCALC and LIST A2DTCOR variables to allow A/D calibration.

Version 2.06 - May 2012

Resolved a bug with temperature A/D coefficients were read from the EPROM, causing the temperature A/D to rail.

Change the minimum setting for the CALZDLY variable from 5 to 1.

Version 2.07 - June 2012

Increased the ID chip programming dwell time from 3.2ms to 10ms.

Version 2.08 - July 2012

Fixed a bug that caused excessive '>' characters to be returned from a reboot command.

Version 2.09 - October 2012

Added a Wiznet FIFO fill test for binary output to increase system stability. Added fast scan mode functionality. Delayed the serial connection prompt output until the boot processes is complete. Fixed a bug that canceled a SAVE in progress if the Ethernet connection was terminated.

Version 2.10 - September 2013

Added SYSLOG client including LIST SYSLOG group. Resolved a bug that caused unexpected characters to be output when channels are railed in raw data. Resolved a bug that prevented raw data to be acquired faster than 600Hz/channel.

Resolved a bug created in V2.09 that prevented correct data collection using an external trigger.

Version 2.11 - March 2014

Resolved a bug created in V2.09 that resulted in very small shifts in the data of module 2 & 3's channel 3 data. This only occurred when collecting data with a period of 25 microseconds. The resolution of the bug included:

- 1) Added close of the binary data socket when a Wiznet buffer overflow occurs.
- 2) Moved packet size calculation to scan start function in order to remove it from the critical data path.
- 3) Removed multiple Wiznet register reads for FIFO level.
- 4) Installed one FIFO level read as in "in line" function to reduce execution time.

Version 2.12 - January 2015

Added the RDOUT command to read the current status of the DOUTs. Re-allocated RAM space to use all of the available RAM. Resolved a bug that produced incorrect time stamps if the product of (period*avg*#channels) > 32767.

Version 2.13 - July 2016

Resolved a bug that did not allow the ZERO.cfg file to be read at boot up.

Version 2.14 - September 2016

Added support for multiple MSCPs with multiple RDS

Version 2.15 - November 2016

Added a 250µs delay to the ID chip read process to increase reliability of the ID chip readings.

Version 2.16 - November 2016

Removed the reading of the ZERO.cfg file at boot up. Added ability to load ZERO.cfg file by ZLOAD command.

Version 2.17- August 2017

Resolved a bug that read the DELTA file on startup.

Version 2.18 - March 2019

Improved ID chip programming reliability.

Version 2.19 - Not Released

Version 2.20 - September 2019

Added support for MPS4164. Added support for dual Telnet connections, with limitations. Corrected an issue with FILE command. Corrected an issue with FTP socket. Updated firmware to support new flash chip memory. This version is backwards compatible and will work in older hardware versions. First module to ship with new flash chip is SN 198.

Version 2.21 - December 2019

Resolved a bug with temperature readings from a TGRAD command. Resolved a bug that prevented the STOP command from stopping the ERAD during a purge.

Version 2.22 - December 2019

Corrected a one-wire timing issue when writing ID chip information.

This page is intentionally left blank

This page is intentionally left blank

Scanivalve

**1722 N. MADSON ST.
LIBERTY LAKE, WA 99019**

**PHONE: 1-800-935-5151
1-509-891-9970
FAX: 1-509-891-9481**

**SCANCO@SCANIVALVE.COM
WWW.SCANIVALVE.COM**

**ERAD4000 SERVICE MANUAL
JANUARY 22, 2020**



Instrumentation Devices Srl
Via Acquanera 29 - 22100 COMO (Italy)
ph +39 031 525 391- fax +39 031 507 984
info@instrumentation.it - www.instrumentation.it